

HEIDELBERG QUICKMASTER DI

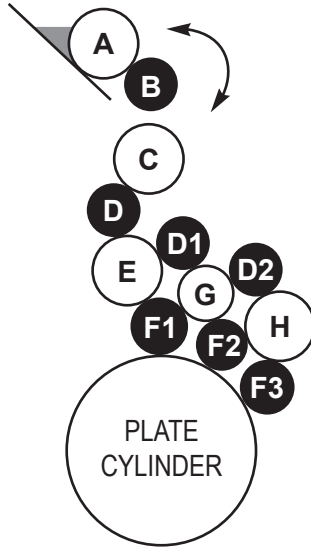

DI 1st. & 2nd. UNITS

● Soft Rubber Roll ○ Not Available from SYN-TAC

Syn-Tac Cat. No.	Key	Description	Mfg. Part #	Roll Dia.	Roll Face Lgth.	Overall Shaft Lgth.
QUICKMASTER DI						
INK SYSTEM ROLLERS						
34H10	F1	1st. INK FORM (yellow)	MV.029.548	2 ⁵ / ₃₂	13 ¹³ / ₃₂	19 ¹ / ₃₂
34H11	F2	2nd. INK FORM (blue)	MV.029.549/01	1 ²⁵ / ₃₂	13 ¹³ / ₃₂	16 ⁹ / ₁₆
34H12	F3	3rd. INK FORM (black)	MV.027.709/04	1 ³¹ / ₃₂	13 ¹³ / ₃₂	18 ²⁹ / ₃₂
34H20	D	INK DISTRIBUTOR (black)	MV.024.476/01	2 ¹ / ₁₆	13 ¹³ / ₃₂	18 ¹⁵ / ₁₆
34H21	D1	INK DISTRIBUTOR (black)	MV.024.478/01	1 ²⁹ / ₃₂	13 ¹³ / ₃₂	19 ¹ / ₂
34H22	D2	INK DISTRIBUTOR (black)	MV.024.479/03	1 ²⁹ / ₃₂	13 ¹³ / ₃₂	17 ¹ / ₃₂
34H30*	B	INK DUCTOR (black)	MV.024.481/04	1 ¹⁹ / ₃₂	13 ¹³ / ₃₂	16 ¹⁷ / ₃₂
34H19	—	BLANKET WASH ROLL	A4.205.121/04	1 ³¹ / ₃₂	13 ²⁵ / ₃₂	13 ²⁵ / ₃₂

* Bearings are NOT included.

DI 3rd. & 4th. UNITS

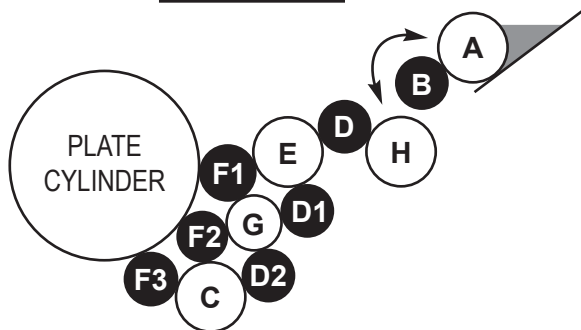

TheRollerStore.com

229-241-8022

HEIDELBERG QUICKMASTER 46 & PRINTMASTER 46

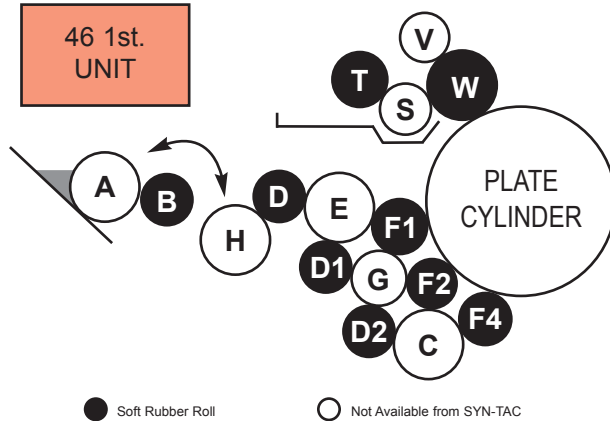

TheRollerStore.com

229-241-8022

Syn-Tac Cat. No.	1st. Unit	2nd. Unit	Description	Mfg. Part #	Roll Dia.	Roll Face Lgth.	Overall Shaft Lgth.
QUICKMASTER 46, PRINTMASTER							
INK SYSTEM ROLLERS							
34H-K1	•	—	KIT (1st unit 7 soft ink rolls)	—	—	—	—
34H-K2	—	-	KIT (2nd unit 8 soft ink rolls)	—	—	—	—
•-34H10	F1	F1	1st. INK FORM (yellow)	MV.024.477/01 A1.009.090	2 ⁵ / ₃₂	13 ¹³ / ₃₂	19 ¹ / ₃₂
•-34H11	F2	F2	2nd. INK FORM (blue)	MV.024.480/02 A1.009.110	1 ²⁵ / ₃₂	13 ¹³ / ₃₂	16 ⁹ / ₁₆
•-34H13	F4		3rd. INK FORM (black)	MV.024.487/03 A1.009.115	1 ³¹ / ₃₂	13 ¹³ / ₃₂	18 ²⁹ / ₃₂
-34H14	—	F5	3rd. INK FORM (red)	MV.025.417/01	1 ³¹ / ₃₂	13 ¹³ / ₃₂	18 ⁵ / ₈
•-34H20	D	D	INK DISTRIBUTOR (black)	MV.024.476/01 A1.009.080	2 ¹ / ₁₆	13 ¹³ / ₃₂	18 ¹⁵ / ₁₆
•-34H21	D1	D1	INK DISTRIBUTOR (black)	MV.024.478/01 A1.009.092	1 ²⁹ / ₃₂	13 ¹³ / ₃₂	19 ¹ / ₂
•-34H22	D2	D2	INK DISTRIBUTOR (black)	MV.024.479/03 A1.009.093	1 ²⁹ / ₃₂	13 ¹³ / ₃₂	17 ¹ / ₃₂
•-34H30*	B	B	INK DUCTOR (black)	MV.024.481/04	1 ¹⁹ / ₃₂	13 ¹³ / ₃₂	16 ¹⁷ / ₃₂
34H18	—	—	BLANKET WASH ROLL	A1.205.512F/	1 ⁵ / ₈	13 ¹ / ₂	15 ⁷ / ₈
DAMPENING UNIT ROLLERS							
34H40*		W1	WATER FORM (shell only serial #956640 and up)	MV.028.411	2 ¹ / ₂	13 ⁵ / ₈	13 ⁵ / ₈
34H42		W1	WATER FORM (complete)	MV.028.411	2 ¹ / ₂	13 ⁵ / ₈	17 ¹¹ / ₃₂
34H41*		W	WATER FORM (shell only serial #955295 - 956639)	MV.024.768 A1.030.024F	2 ¹ / ₂	13 ⁵ / ₈	13 ⁵ / ₈
34H41*		W	WATER FORM (shell only 70 duro)	MV.024.768 A1.030.024F	2 ¹ / ₂	13 ⁵ / ₈	13 ⁵ / ₈
34H43		W	WATER FORM (complete 70 duro)	MV.028.768 A1.030.024F	2 ¹ / ₂	13 ⁵ / ₈	17 ¹¹ / ₃₂
34H50*		T	WATER DISTRIBUTOR (serial #955001 & up shell only)	MV.024.675	2 ¹ / ₈	13 ¹ / ₂	13 ²⁵ / ₃₂
34H51*		T1	WATER METERING (shell only)	MV.028.470	1 ³ / ₄	13 ⁷ / ₈	13 ⁷ / ₈
34H52		T	WATER DISTRIBUTOR (PrintMaster)	A1.030.236	2 ¹ / ₈	13 ⁵ / ₈	15 ¹ / ₂

•-The ink train soft rubber roller kit includes these rolls

* Bearings are NOT included.

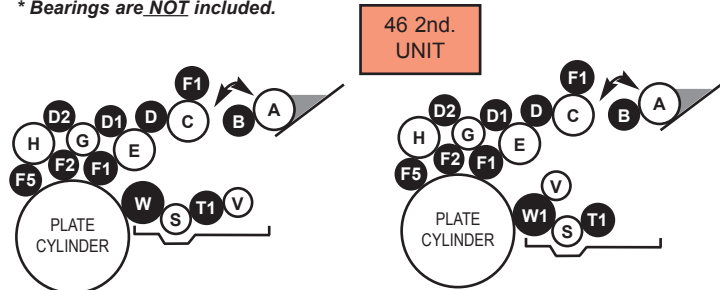

Serial # 955295 to 956639

Serial # 956640 and up



HEIDELBERG GTO MODELS 46

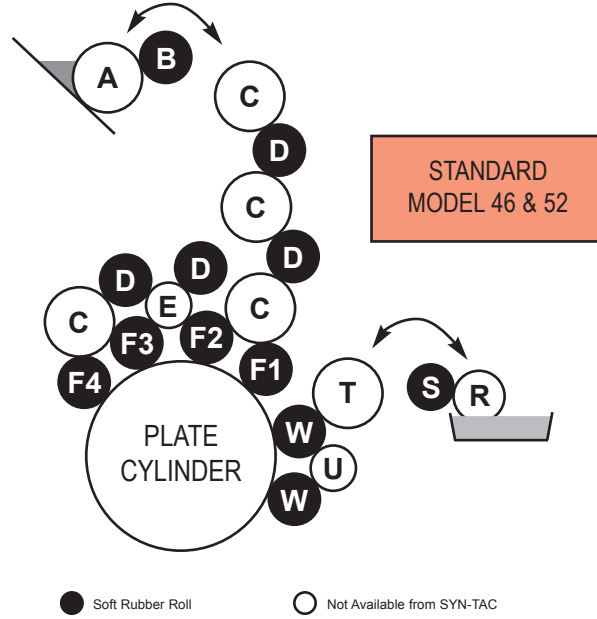

TheRollerStore.com

229-241-8022

Syn-Tac Cat. No.	Key	Description	Mfg. Color	Roll Dia.	Roll Face Lgth.	Overall Shaft Lgth.
GTO MODEL 46						
INK SYSTEM ROLLERS						
46H10-Y	F1	INK FORM	YELLOW	1 ¹⁵ / ₁₆	17 ³¹ / ₃₂	21 ³ / ₃₂
46H10-B	F2	INK FORM	BLUE	1 ²⁵ / ₃₂	17 ³¹ / ₃₂	21 ³ / ₃₂
46H10-W	F3	INK FORM	WHITE	1 ²⁷ / ₃₂	17 ³¹ / ₃₂	21 ³ / ₃₂
46H10-R	F4	INK FORM	RED	2	17 ³¹ / ₃₂	21 ³ / ₃₂
46H10-B	D	INK DISTRIBUTOR	BLUE	1 ²⁵ / ₃₂	17 ³¹ / ₃₂	21 ³ / ₃₂
46H10-B	B	INK DUCTOR	BLUE	1 ²⁵ / ₃₂	17 ³¹ / ₃₂	21 ³ / ₃₂
DAMPENING UNIT ROLLERS						
46H10-G	W	WATER FORM	GREEN	1 ¹³ / ₁₆	18 ¹¹ / ₃₂	21 ³ / ₃₂
46H10-G	S	WATER DUCTOR	GREEN	1 ¹³ / ₁₆	18 ¹¹ / ₃₂	21 ³ / ₃₂
46H11-G	W	3M WATER FORM (3M sleeve #18519 <u>not</u> included)	GREEN	1 ⁷ / ₈	18 ¹¹ / ₃₂	21 ³ / ₃₂
46H12-G	W	BAREBACK WATER FORM	GREEN	2 ¹ / ₃₂	18 ¹⁹ / ₃₂	21 ³ / ₃₂
NUMBERING & IMPRINTING ROLLERS						
46H10-N	F5	INK FORM	—	1 ⁹ / ₃₂	17 ⁹ / ₁₆	—
46H10-N	D1	INK DISTRIBUTOR	—	1 ⁹ / ₃₂	17 ⁹ / ₁₆	—
46H10-N	B1	INK DUCTOR	—	1 ⁹ / ₃₂	17 ⁹ / ₁₆	—

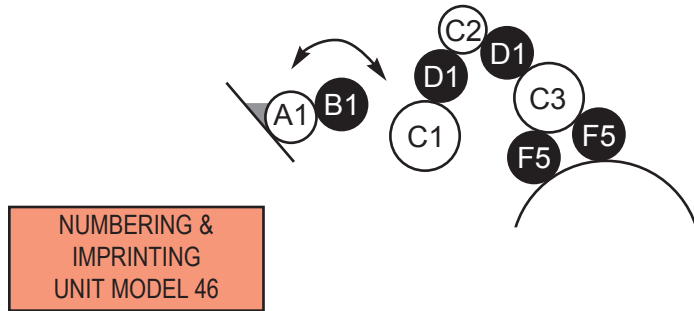



SYN-TAC

HEIDELBERG GTO

HEIDELBERG GTO MODELS 52

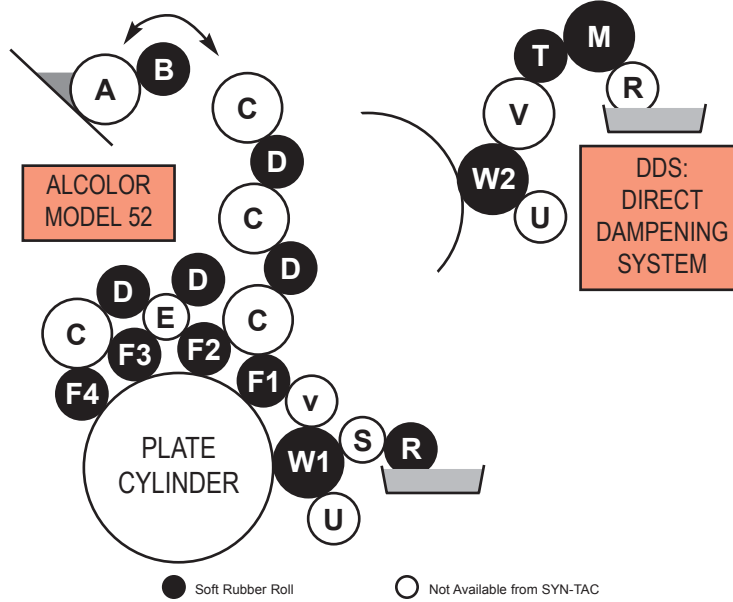

TheRollerStore.com

229-241-8022

Syn-Tac Cat. No.	Key	Description	Mfg. Color	Roll Dia.	Roll Face Lgth.	Overall Shaft Lgth.
GTO MODEL 52						
INK SYSTEM ROLLERS						
52H10-Y	F1	INK FORM	YELLOW	1 ¹⁵ / ₁₆	20 ¹ / ₄	23 ¹⁵ / ₃₂
52H10-B	F2	INK FORM	BLUE	1 ²⁵ / ₃₂	20 ¹ / ₄	23 ¹⁵ / ₃₂
52H10-W	F3	INK FORM	WHITE	1 ²⁷ / ₃₂	20 ¹ / ₄	23 ¹⁵ / ₃₂
52H10-R	F4	INK FORM	RED	2	20 ¹ / ₄	23 ¹⁵ / ₃₂
52H10-B	D	INK DISTRIBUTOR	BLUE	1 ²⁵ / ₃₂	20 ¹ / ₄	23 ¹⁵ / ₃₂
52H10-B	B	INK DUCTOR	BLUE	1 ²⁵ / ₃₂	20 ¹ / ₄	23 ¹⁵ / ₃₂
DUCTOR DAMPENING UNIT ROLLERS						
52H10-G	W	WATER FORM	GREEN	1 ¹³ / ₁₆	20 ²⁵ / ₃₂	23 ¹⁵ / ₃₂
52H10-G	S	WATER DUCTOR	GREEN	1 ¹³ / ₁₆	20 ²⁵ / ₃₂	23 ¹⁵ / ₃₂
52H11-G	W	3M WATER FORM (3M sleeve #18822 <u>not</u> included)	GREEN	1 ⁷ / ₈	20 ²⁵ / ₃₂	23 ¹⁵ / ₃₂
52H12-G	W	BAREBACK WATER FORM	GREEN	2 ¹ / ₃₂	20 ¹⁵ / ₁₆	23 ¹⁵ / ₃₂
ALCOLOR CONTINUOUS DAMPENING ROLLERS						
52H15-G	W1	ALCOLOR DAMPENING FORM (complete)	—	2 ¹¹ / ₁₆	20 ¹³ / ₃₂	21 ¹³ / ₃₂
52H55-G	R	ALCOLOR DAMPENING PAN (complete)	—	2 ²⁵ / ₃₂	20 ⁷ / ₈	—
DIRECT DAMPENING SYSTEM						
52H13-G	W2	WATER FORM	GREEN	2 ³ / ₁₆	21 ¹ / ₄	23 ¹⁵ / ₃₂
52H13-M*	M	METERING	—	2 ³ / ₁₆	21	21
52H13-T*	T	TRANSFER	—	1 ¹⁹ / ₃₂	20 ¹ / ₂	20 ¹ / ₂
NUMBERING & IMPRINTING ROLLERS						
52H10-N	F5	INK FORM	—	1 ⁹ / ₃₂	19 ¹¹ / ₁₆	—
52H10-N	D1	INK DISTRIBUTOR	—	1 ⁹ / ₃₂	19 ¹¹ / ₁₆	—
52H10-N	B1	INK DUCTOR	—	1 ⁹ / ₃₂	19 ¹¹ / ₁₆	—

* Bearings are NOT included.

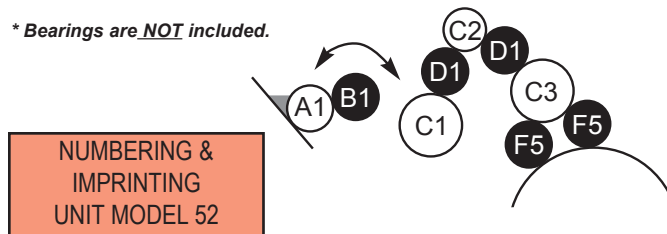

HEIDELBERG TOK (LONG)

Serial number 496600 & UP,
 INCLUDING numbers 493726, 495147, 495313, 495484, 495561, 495586,
 495961**, 496054, 496055, 496060, 496189, & 496277

**Note: number 495961 uses 27H51-L, 27H53-L, & 27H55-L only

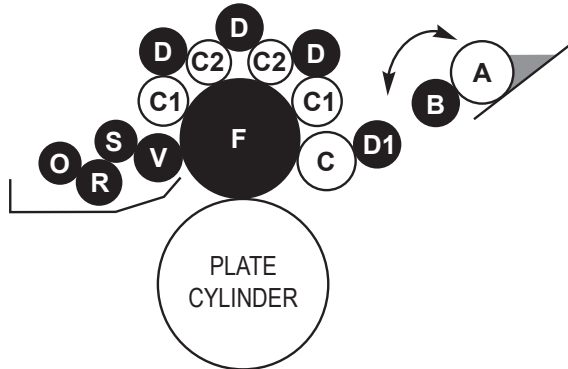

● Soft Rubber Roll ○ Not Available from SYN-TAC

Syn-Tac Cat. No.	Long	Short	Description	Mfg. Part #	Roll Dia.	Roll Face Lgth.	Overall Shaft Lgth.
TOK (LONG & SHORT)							
INK SYSTEM ROLLERS							
27H10-L	F	—	INK FORM	22.010.020F/01	4 ³ / ₁₆	10 ²⁷ / ₃₂	15 ²¹ / ₃₂
27H10-S	—	F	INK FORM	22.010.020F/a	4 ³ / ₁₆	10 ¹ / ₂	15 ²¹ / ₃₂
27H20-L*	D	—	INK RIDER	22.009.008F/02	1 ¹ / ₂	10 ¹⁵ / ₁₆	14 ¹¹ / ₁₆
27H20-S*	—	D	INK RIDER	22.009.008F/01c	1 ¹ / ₂	10 ⁷ / ₁₆	14 ¹¹ / ₁₆
27H21-L*	D1	—	INK TRANSFER	22.010.050F/01	1 ³ / ₈	10 ²¹ / ₃₂	16 ⁵ / ₈
27H21-S*	—	D1	INK TRANSFER	22.010.050F/b	1 ³ / ₈	10 ¹⁵ / ₃₂	16 ⁵ / ₈
27H30-L*	B	—	INK DUCTOR	22.010.090F/03	1 ¹¹ / ₃₂	10 ¹⁹ / ₃₂	13 ⁵ / ₃₂
27H30-S*	—	B	INK DUCTOR	22.010.090F/02d	1 ¹¹ / ₃₂	10 ⁹ / ₁₆	13 ⁵ / ₃₂
WATER SYSTEM ROLLERS							
27H51-L*	S	—	DAMPENING TRANSFER	22.030.048F/02	1 ¹ / ₄	11 ¹ / ₈	16 ¹ / ₁₆
27H51-S*	—	S	DAMPENING TRANSFER	22.030.048F/01f	1 ¹ / ₄	10 ²⁵ / ₃₂	16 ¹ / ₁₆
27H53-L*	O	—	SQUEEZE	22.030.040F04	1 ¹⁹ / ₃₂	11 ¹⁵ / ₃₂	13 ⁹ / ₃₂
27H53-S*	—	O	SQUEEZE	22.030.040F03a	1 ¹⁹ / ₃₂	11 ¹ / ₃₂	13 ⁹ / ₃₂
27H55-L*	R	—	FOUNTAIN	22.030.020F/05	1 ¹¹ / ₁₆	11 ¹⁵ / ₃₂	14 ⁹ / ₁₆
27H55-S*	—	R	FOUNTAIN	22.030.020F/04a	1 ¹¹ / ₁₆	11 ¹ / ₁₆	14 ⁹ / ₁₆
27H59-L*	V	—	DISTRIBUTOR	22.030.055F/01	1 ¹¹ / ₁₆	11 ⁵ / ₃₂	17 ¹ / ₁₆
27H59-S*	—	V	DISTRIBUTOR	22.030.055F/a	1 ¹¹ / ₁₆	10 ²³ / ₃₂	17 ¹ / ₁₆

HEIDELBERG TOK (SHORT)

Serial number 496599 & down,
 EXCEPT numbers 493726, 495147, 495313, 495484, 495561, 495586,
 495961**, 496054, 496055, 496060, 496189, & 496277

**Note: number 495961 uses 27H10-S, 27H20-S, 27H21-S, 27H30-S, &
 27H59-S only

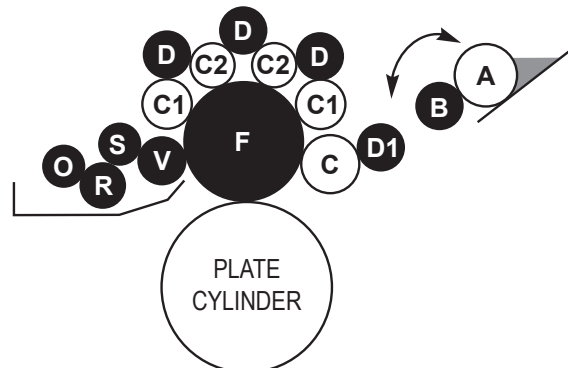

* Bearings are NOT included.

TheRollerStore.com

229-241-8022

HEIDELBERG 10 X 15 WINDMILL

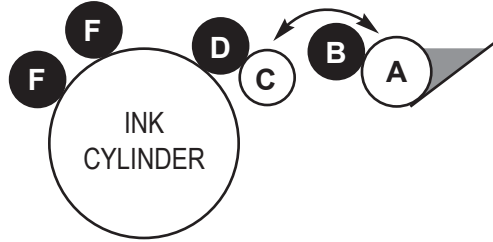

● Soft Rubber Roll ○ Not Available from SYN-TAC

Syn-Tac Cat. No.	Key	Description	Mfg. Part #	Roll Dia.	Roll Face Lgth.	Overall Shaft Lgth.
INK SYSTEM ROLLERS						
37H11	F	INK FORM	01.009.020	2 ¹ / ₃₂	14 ⁹ / ₁₆	19 ¹¹ / ₃₂
37H10*	D	INK DISTRIBUTOR	01.009.020	2 ¹ / ₃₂	14 ⁹ / ₁₆	19 ¹¹ / ₃₂
37H10*	B	INK DUCTOR	01.009.020	2 ¹ / ₃₂	14 ⁹ / ₁₆	19 ¹¹ / ₃₂

* Bearings are NOT included.

PRINT WORKS CHEMICAL TIP:

Many press users don't wash up the press at the end of the day. This permits dust and dirt to accumulate in the inking system and invites many problems. It's not good roller care either.

If it is policy not to wash up at night, it is advisable to give the press a good cleaning on Friday. Wash the ink off your rollers with a good wash like X75-122 and X75-123. Once the ink has been removed apply a good deglazer like X75-111, and rinse with X75-123. Your press rollers will be clean and can rest over the weekend.

Good housekeeping pays off in better production and higher quality with less down time and fewer service calls. Ink and water balance is easier to maintain if the rollers are free of glaze. Hickeys are less of a problem because dried ink particles and dirt do not accumulate in the inking system.

TheRollerStore.com

229-241-8022

HEIDELBERG SPEEDMASTER 52

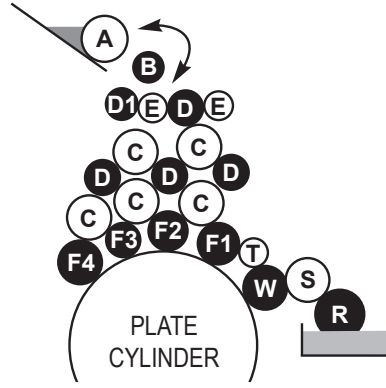

● Soft Rubber Roll ○ Not Available from SYN-TAC

Syn-Tac Cat. No.	Key	Description	Mfg. Color	Roll Dia.	Roll Face Lgth.	Overall Shaft Lgth.
HEIDELBERG SPEEDMASTER 52						
INK SYSTEM ROLLERS						
52SM10	F1	1st INK FORM	WHITE	2 ¹⁷ / ₃₂	21 ³ / ₁₆	22 ⁷ / ₃₂
52SM11	F2	2nd INK FORM	BLUE	2 ¹³ / ₃₂	21 ³ / ₁₆	22 ⁷ / ₃₂
52SM12	F3	3rd INK FORM	RED	2 ¹ / ₈	21 ³ / ₁₆	22 ⁷ / ₃₂
52SM13	F4	4th INK FORM	YELLOW	2 ¹¹ / ₁₆	21 ³ / ₁₆	22 ⁷ / ₃₂
52SM20	D	INK TRANSFER (large)	GREEN	2 ⁵ / ₃₂	20 ¹⁵ / ₁₆	23 ¹⁵ / ₁₆
52SM21	D1	INK TRANSFER (small)	BLACK	1 ³ / ₃₂	20 ¹⁵ / ₁₆	23 ¹⁵ / ₁₆
52SM30	B	INK DUCTOR	VIOLET	1 ²⁹ / ₃₂	20 ¹⁵ / ₃₂	23 ¹⁵ / ₁₆
ALCOLOR DAMPENING UNIT ROLLERS						
52SM44	W	ALCOLOR WATER FORM	—	2 ¹¹ / ₁₆	20 ⁶³ / ₆₄	—
52SM55	R	ALCOLOR WATER PAN	—	2 ²⁹ / ₃₂	21 ⁹ / ₁₆	—

HEIDELBERG MO-43

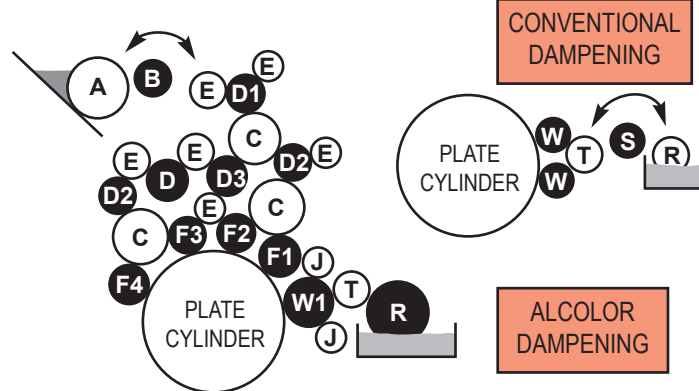

● Soft Rubber Roll ○ Not Available from SYN-TAC

HEIDELBERG MO-43						
INK SYSTEM ROLLERS						
43H10	F1,D	1st INK FORM and DIST.	WHITE	2 ¹ / ₄	25 ³ / ₄	28 ²³ / ₃₂
43H11	F2,D1	2nd INK FORM and DIST.	BLUE	2 ³ / ₃₂	25 ³ / ₄	28 ²³ / ₃₂
43H12	F3,D2	3rd INK FORM and DIST.	RED	2 ¹ / ₃₂	25 ³ / ₄	28 ²³ / ₃₂
43H13	F4,D3	4th INK FORM and DIST.	YELLOW	2 ³ / ₁₆	25 ³ / ₄	28 ²³ / ₃₂
43H30	B	INK DUCTOR	RED	2 ¹ / ₃₂	25 ³ / ₄	28 ²³ / ₃₂
ALCOLOR DAMPENING UNIT ROLLERS						
43H44	W1	ALCOLOR WATER FORM	—	2 ¹¹ / ₁₆	25 ²⁹ / ₃₂	—
43H55	R	ALCOLOR WATER PAN	—	3 ¹¹ / ₃₂	26 ¹⁷ / ₃₂	—
CONVENTIONAL DAMPENING UNIT ROLLERS						
43H40	W S	WATER FORM & DUCTOR	GREEN	1 ⁵⁷ / ₆₄	26 ³ / ₃₂	28 ²³ / ₃₂
43H42	W	BAREBACK WATER FORM	GREEN	2 ¹ / ₆₄	26 ³ / ₃₂	28 ²³ / ₃₂

TheRollerStore.com

229-241-8022

HEIDELBERG KORD 62

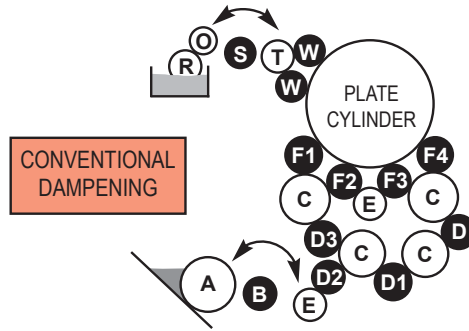

● Soft Rubber Roll ○ Not Available from SYN-TAC

Syn-Tac Cat. No.	Key	Description	Mfg. Color	Roll Dia.	Roll Face Lgth.	Overall Shaft Lgth.
HEIDELBERG KORD 62						
INK SYSTEM ROLLERS						
62KD10*	F1, D	1st INK FORM and DIST.	BLUE	2 ¹⁷ / ₆₄	24 ³⁹ / ₆₄	26 ³ / ₈
62KD11*	F2, D1	2nd INK FORM and DIST.	WHITE	2 ⁷ / ₆₄	24 ³⁹ / ₆₄	26 ³ / ₈
62KD12*	F3, D2	3rd INK FORM and DIST.	RED	2 ¹ / ₃₂	24 ³⁹ / ₆₄	26 ³ / ₈
62KD13*	F4, D3	4th INK FORM and DIST.	BROWN	2 ³ / ₁₆	24 ³⁹ / ₆₄	26 ³ / ₈
62KD30*	B	INK DUCTOR	RED	2 ¹ / ₃₂	24 ³⁹ / ₆₄	26 ³ / ₈
CONVENTIONAL DAMPENING UNIT ROLLERS						
62KD40*	W, S	WATER FORM/DUCTOR (os)	GREEN	1 ⁵⁷ / ₆₄	25	26 ³ / ₈
62KD41*	W	3M WATER FORM (3M sleeve #19728 <u>not</u> included)	GREEN	1 ⁶³ / ₆₄	25	26 ³ / ₈
62KD42*	W	WATER FORM BAREBACK	GREEN	2 ¹ / ₃₂	25	26 ³ / ₈

HEIDELBERG KORD 64

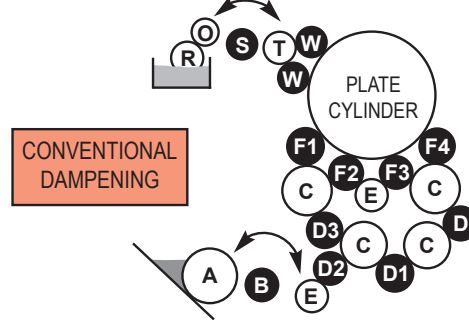

● Soft Rubber Roll ○ Not Available from SYN-TAC

HEIDELBERG KORD 64						
INK SYSTEM ROLLERS						
64KD15*	F1, D	1st INK FORM and DIST.	BLUE	2 ¹⁷ / ₆₄	25 ²⁵ / ₆₄	27 ⁶¹ / ₆₄
64KD16*	F2, D1	2nd INK FORM and DIST.	WHITE	2 ⁷ / ₆₄	25 ²⁵ / ₆₄	27 ⁶¹ / ₆₄
64KD17*	F3, D2	3rd INK FORM and DIST.	RED	2 ¹ / ₃₂	25 ²⁵ / ₆₄	27 ⁶¹ / ₆₄
64KD18*	F4, D3	4th INK FORM and DIST.	BROWN	2 ³ / ₁₆	25 ²⁵ / ₆₄	27 ⁶¹ / ₆₄
64KD31*	B	INK DUCTOR	RED	2 ¹ / ₃₂	25 ²⁵ / ₆₄	27 ⁶¹ / ₆₄
CONVENTIONAL DAMPENING UNIT ROLLERS						
64KD40*	W, S	WATER FORM/DUCTOR (os)	GREEN	1 ⁵⁷ / ₆₄	26 ³ / ₈	28 ¹⁵ / ₆₄
64KD41*	W	3M WATER FORM (3M sleeve #19728 <u>not</u> included)	GREEN	1 ⁶³ / ₆₄	26 ³ / ₈	28 ¹⁵ / ₆₄
64KD42*	W	WATER FORM BAREBACK	GREEN	2 ¹ / ₃₂	26 ³ / ₈	28 ¹⁵ / ₆₄

* Bearings are NOT included.

TheRollerStore.com

229-241-8022

HEIDELBERG SPEEDMASTER 102 SORS PRE DRUPA
Serial # below 523-898

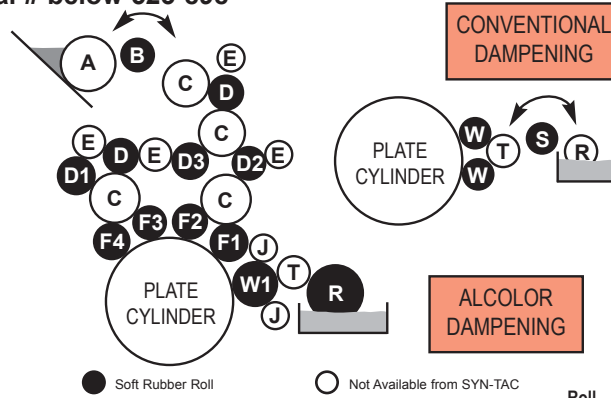

● Soft Rubber Roll ○ Not Available from SYN-TAC

Syn-Tac Cat. No.	Key	Description	Mfg. Color	Roll Dia.	Roll Face Lgth.	Overall Shaft Lgth.
------------------	-----	-------------	------------	-----------	-----------------	---------------------

HEIDELBERG SORS PRE DRUPA

INK SYSTEM ROLLERS

102SPD10	F1, D	1st INK FORM and DIST.	WHITE	2 ³¹ / ₆₄	40 ²⁵ / ₆₄	42 ²⁷ / ₃₂
102SPD11	F2, D1	2nd INK FORM and DIST.	BLUE	2 ¹⁷ / ₆₄	40 ²⁵ / ₆₄	42 ²⁷ / ₃₂
102SPD12	F3, D2	3rd INK FORM and DIST.	RED	2 ²⁵ / ₆₄	40 ²⁵ / ₆₄	42 ²⁷ / ₃₂
102SPD13	F4, D3	4th INK FORM and DIST.	YELLOW	2 ¹⁹ / ₃₂	40 ²⁵ / ₆₄	42 ²⁷ / ₃₂
102SPD30	B	INK DUCTOR	BLUE	2 ¹⁷ / ₆₄	40 ²⁵ / ₆₄	42 ²⁷ / ₃₂

CONVENTIONAL DAMPENING UNIT ROLLERS

102SPD40	W, S	WATER FORM/DUCTOR (os)	GREEN	2 ³¹ / ₆₄	41 ⁹ / ₆₄	42 ²⁷ / ₃₂
102SPD42	W	WATER FORM BAREBACK	GREEN	2 ¹⁹ / ₃₂	41 ⁹ / ₆₄	42 ²⁷ / ₃₂
102SPD50	S	WATER DUCTOR (new style)	GREEN	2 ³¹ / ₆₄	41 ⁴⁷ / ₆₄	43 ²⁷ / ₆₄

ALCOLOR DAMPENING UNIT ROLLERS

102SPD44	W1	ALCOLOR DAMPENING FORM	—	3 ⁵ / ₆₄	40 ¹⁵ / ₁₆	—
102SPD55	R	ALCOLOR DAMPENING PAN	—	4 ¹ / ₄	41 ⁴⁷ / ₆₄	—

HEIDELBERG SPEEDMASTER 102 SORS DRUPA
Serial # 523-898 & up

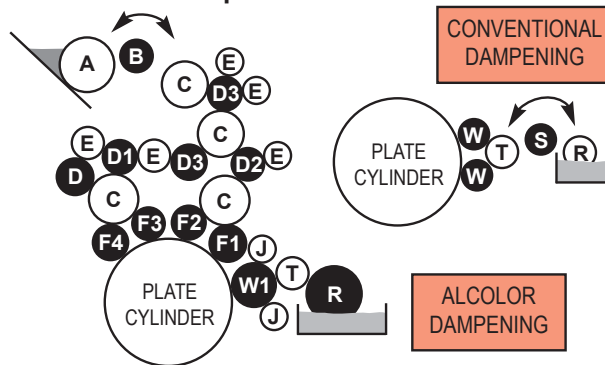

HEIDELBERG SORS DRUPA

INK SYSTEM ROLLERS

102SD10	F1, D	1st INK FORM and DIST.	WHITE	2 ²³ / ₆₄	40 ³ / ₄	42 ⁵¹ / ₆₄
102SD11	F2, D1	2nd INK FORM and DIST.	BLUE	2 ²⁷ / ₃₂	40 ³ / ₄	42 ⁵¹ / ₆₄
102SD12	F3, D2	3rd INK FORM and DIST.	RED	2 ¹⁹ / ₃₂	40 ³ / ₄	42 ⁵¹ / ₆₄
102SD13	F4, D3	4th INK FORM and DIST.	YELLOW	3 ⁹ / ₆₄	40 ³ / ₄	42 ⁵¹ / ₆₄
102SD30	B	INK DUCTOR	WHITE	2 ²³ / ₆₄	40 ³ / ₄	42 ⁵¹ / ₆₄
102SD31	B	INK DUCTOR (tube style)	BROWN	2 ²³ / ₆₄	40 ³ / ₄	42 ³ / ₁₆
102SD32	B	INK DUCTOR SHORT (n/s)	—	2 ²³ / ₆₄	40 ³ / ₄	42 ³ / ₁₆

CONVENTIONAL DAMPENING UNIT ROLLERS

102SPD40	W, S	WATER FORM/DUCTOR (os)	GREEN	2 ³¹ / ₆₄	41 ⁹ / ₆₄	42 ²⁷ / ₃₂
102SPD42	W	WATER FORM BAREBACK	GREEN	2 ¹⁹ / ₃₂	41 ⁹ / ₆₄	42 ²⁷ / ₃₂
102SPD50	S	WATER DUCTOR (new style)	GREEN	2 ³¹ / ₆₄	41 ⁴⁷ / ₆₄	43 ²⁷ / ₆₄

ALCOLOR DAMPENING UNIT ROLLERS

102SPD44	W1	ALCOLOR DAMPENING FORM	—	3 ⁵ / ₆₄	40 ¹⁵ / ₁₆	—
102SPD55	R	ALCOLOR DAMPENING PAN	—	4 ¹ / ₄	41 ⁴⁷ / ₆₄	—

TheRollerStore.com

229-241-8022