

Date of Installation : _____

Unit Serial Number : _____

Kompac Dealer : _____

Kompac®



A DIVISION OF DAY INTERNATIONAL, INC.



DAY INTERNATIONAL, INC.

Image Transfer Group

Kompac



HMD 6112

Parts Catalog # 090282

159 DWIGHT PLACE , FAIRFIELD , NEW JERSEY 07004

TEL: 973-227-8611 / 800-541-5702

FAX: 973-227-7532

HMD 6112 UNIT: P/N 093610
HMD 6112-KM UNIT: P/N 093600

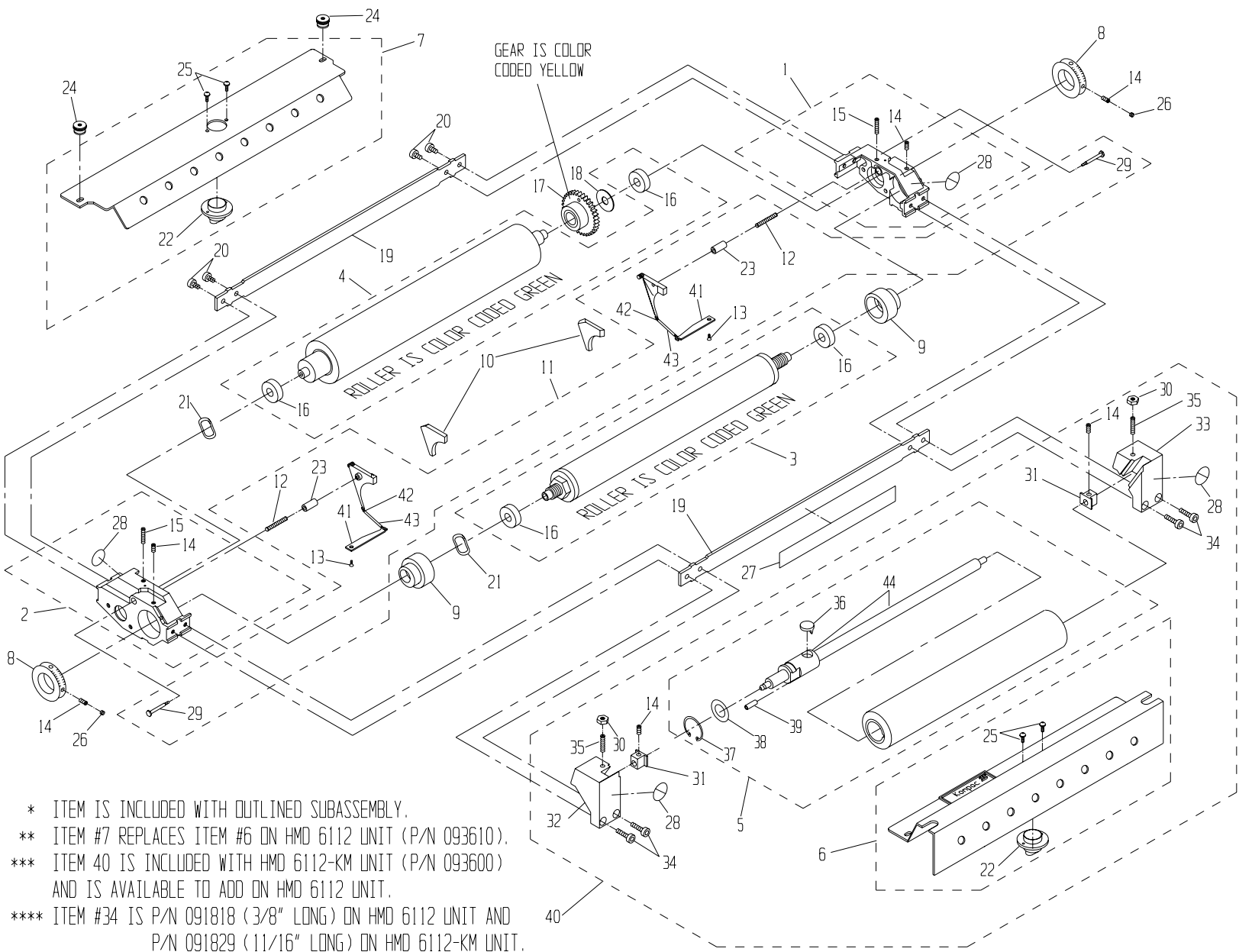

* ITEM IS INCLUDED WITH OUTLINED SUBASSEMBLY.
** ITEM #7 REPLACES ITEM #6 ON HMD 6112 UNIT (P/N 093610).
*** ITEM 40 IS INCLUDED WITH HMD 6112-KM UNIT (P/N 093600) AND IS AVAILABLE TO ADD ON HMD 6112 UNIT.
**** ITEM #34 IS P/N 091818 (3/8" LONG) ON HMD 6112 UNIT AND P/N 091829 (11/16" LONG) ON HMD 6112-KM UNIT.

44	091261	SHAFT ASSY. S.S.	*	30	091982	#10-32 NUT	2	15	091814	#10-24 X 3/4 SET SCREW	*
43	092259	SPRING COVER	*	29	092303	SHOULDER SCREW	*	14	091811	#10-24 X 1/4 SET SCREW	4*
42	092236	TAB SPRING	*	28	092601	INWARD NIP SYMBOL	2*	13	091802	#3-48 X 1/4 FLAT HD SCREW	*
41	092234	TAB	*	27	092494	WARNING STICKER	1	12	092238	COMPRESSION SPRING	*
40	096560	KOLORMATE MODEL 60	***	26	091810	#10-24 X 1/8 SLOT SET SCW	2	11	092290	BACKING PLATE KIT (L & R)	1
39	091949	SPRING PIN	*	25	091806	#6-32 X 3/8 PHILLIPS HD SCW	*	10	092370	KOMPAC SEAL SET (L & R)	1
38	091965	WASHER	*	24	092691	COVER NUT	2	9	092291	ECCENTRIC	2
37	091997	RETAINING CLIP	*	23	092304	GUIDE PIN	*	8	092222	METERING GAUGE	2
36	091117	DRIVE SHAFT FOLLOWER	*	22	092604	NOZZLE	*	7	092620	13" COVER ASSEMBLY	1**
35	091851	#10-32 X 1 SET SCREW	2	21	092491	WAVE WASHER	2	6	091350	13" COVER ASSY (OSC)	**
34	****	#10-24 SOCKET HEAD SCREW	4	20	091818	#10-24 X 3/8 SOC HD SCREW	4	5	091306	ASSY, 13" OSC., LONG STROKE	1
33	091017	R.H. OSC. END BLOCK	1	19	092496	13" TIE BAR	2	4	092470	13" FORM ROLLER W/B	1
32	091018	L.H. OSC. END BLOCK	1	18	092415	THRUST WASHER	1	3	092460	13" METERING ROLLER W/B	1
31	091219	ALIGNMENT BLOCK	2	17	092860	GEAR CLUTCH ASSY, HMD 600	1	2	092210	L.H. END FRAME ASSY	1
ITEM#	PART #	DESCRIPTION	QTY	16	092401	BEARING	*	1	092200	R.H. END FRAME ASSY	1

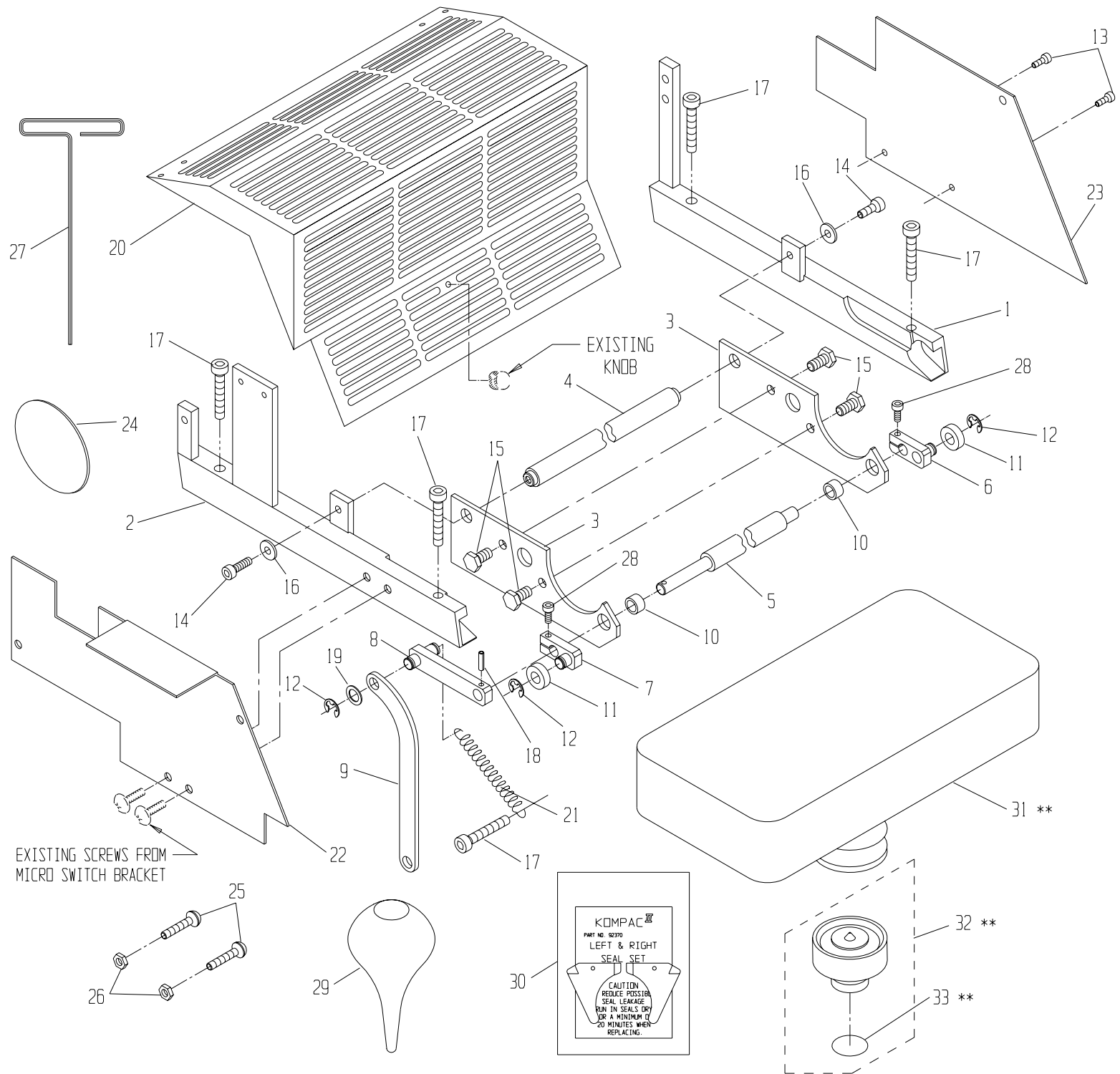

EXISTING SCREWS FROM MICRO SWITCH BRACKET

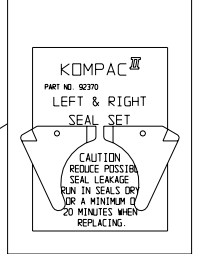

* ITEM IS INCLUDED WITH OUTLINED SUBASSEMBLY.

** ITEMS 31, 32 & 33 ARE NOT INCLUDED WITH BRACKET KIT (P/N 093770).

ITEM	PART NO.	DESCRIPTION	QTY.
30	092370	KOMPAC SEAL SET (L & R)	1
29	092778	KOMPAC SYRINGE	1
28	091845	#10-32 X 3/8" SOCKET HD CAP SCW	2
27	090755	3/32" HEX T-WRENCH	1
26	091968	#10-24 NUT, LOCKING	2
25	091815	#10-24 x 1" BUTTON HEAD CAP SCW	2
24	093923	STICKER, 3-5/8"	1
23	093763	SAFETY PLATE, FAR-SIDE	1
22	093764	SAFETY PLATE, OP-SIDE	1
21	094324	SPRING, EXTENSION	1
20	093765	SAFETY COVER, HMD 6112	1
19	091950	WASHER, FLAT, 5/16"	1
18	091945	ROLL PIN, 1/8" x 1/2"	1
17	091762	SOCKET HD CAP SCREW, M6 x 35mm	5
16	091955	WASHER, FLAT	2
15	091867	HEX HEAD BOLT, 1/4"-20 x 1/2"	4
14	091842	SOCKET HD CAP SCW, #10-32x5/8"	2
13	091799	SOCKET HEAD CAP SCW, #6-32x1/2"	2
12	091994	E-RING, 1/4"	3
11	093766	BEARING, 8 x 16mm	2
10	093767	SLEEVE BEARING	2
9	093769	EXTENTION ARM	1
8	093768	LIFT ARM	1
7	093777	CAM ARM, OP-SIDE	1
6	093776	CAM ARM, FAR-SIDE	1
5	093775	ADJUSTING BAR	1
4	093774	TIE BAR	1
3	093773	PLATE SUPPORT	2
2	093772	BAR SUPPORT, OP-SIDE	1
1	093771	BAR SUPPORT, FAR-SIDE	1
33	092765	O-RING	*
32	092780	LOW PROFILE DISP. VALVE ASSY	**
31	092777	LOW PROFILE CALIBRATED BOTTLE	**