

Date of Installation : _____

Unit Serial Number : _____

Kompac Dealer : _____

Kompac®



A DIVISION OF DAY INTERNATIONAL, INC.



DAY INTERNATIONAL, INC.

Image Transfer Group

Kompac



AF 17 / 17G

Parts Catalog # 090234

159 DWIGHT PLACE , FAIRFIELD , NEW JERSEY 07004

TEL: 973-227-8611 / 800-541-5702

FAX: 973-227-7532

AF 17 UNIT: P/N 93100
 AF 17-KM UNIT: P/N 93310

TheRollerStore.com ~ 229.247.8022
 AF 17G UNIT: P/N 93080
 AF 17G-KM UNIT: P/N 93320

PARTS CATALOG #90234 REV 2

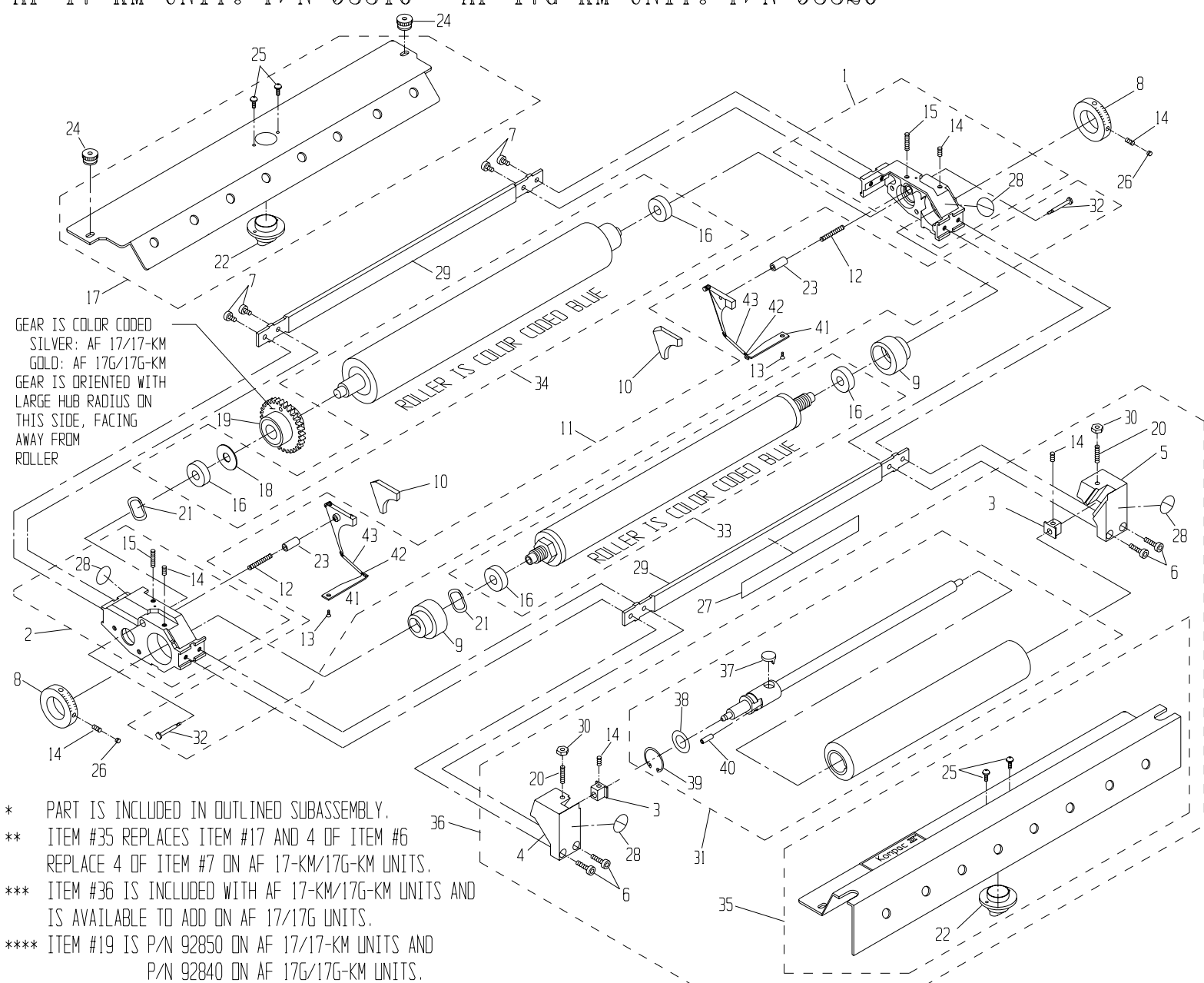

* PART IS INCLUDED IN OUTLINED SUBASSEMBLY.
 ** ITEM #35 REPLACES ITEM #17 AND 4 OF ITEM #6
 REPLACE 4 OF ITEM #7 ON AF 17-KM/17G-KM UNITS.
 *** ITEM #36 IS INCLUDED WITH AF 17-KM/17G-KM UNITS AND IS AVAILABLE TO ADD ON AF 17/17G UNITS.
 **** ITEM #19 IS P/N 92850 ON AF 17/17-KM UNITS AND P/N 92840 ON AF 17G/17G-KM UNITS.

ITEM#	PART #	DESCRIPTION	QTY
43	92259	SPRING COVER	*
42	92236	BACKING PLATE TAB SPRING	*
41	92234	BACKING PLATE TAB	*
40	91949	SPRING PIN	*
49	91997	OSC. RETAINING CLIP	*
48	91965	OSC. RETAINING WASHER	*
37	91111	OSC. DRIVE SHAFT FOLLOWER	*
36	96520	KOLORMATE MODEL 20	***
35	91320	11" OSC COVER ASSY	**
34	92410	11" FORM ROLLER W/B	1
33	92400	11" METERING ROLLER W/B	1
32	92303	SHOULDER SCREW	*
31	91302	11" OSC. PARTS ASSY	1

30	91982	#10-32 NUT	2
29	92492	11" TIE BAR	2
28	92601	INWARD NIP SYMBOL	2*
27	92494	WARNING DECAL	1
26	91810	#10-24 X 1/8 SLOT SET SCW	2
25	91806	#6-32 X 3/8 PHILLIPS HD SCW	*
24	92691	COVER NUT	2
23	92304	GUIDE PIN	*
22	92604	NOZZLE	*
21	92491	WAVE WASHER	2
20	91851	#10-32 x 1 SET SCREW	2
19	****	GEAR CLUTCH ASSY	1
18	92415	THRUST WASHER	*
17	92600	11" COVER ASSEMBLY	**
16	92401	BEARING	*

15	91814	#10-24 X 3/4 STUD	*
14	91811	#10-24 X 1/4 SET SCREW	4*
13	91802	#3-48 X 1/4 FLAT HD SCREW	*
12	92238	COMPRESSION SPRING	*
11	92290	BACKING PLATE KIT (L & R)	1
10	92370	SEAL SET (L & R)	1
9	92291	ECCENTRIC	2
8	92222	METERING GAUGE	2
7	91818	#10-24 x 3/8 SOCKET HD SCREW	8**
6	91829	#10-24 x 11/16 SDC HD SCREW	4**
5	91017	R.H. OSC. END BLOCK	1
4	91018	L.H. OSC. END BLOCK	1
3	91219	ALIGNMENT BLOCK	2
2	92210	L.H. END FRAME ASSY	1
1	92200	R.H. END FRAME ASSY	1

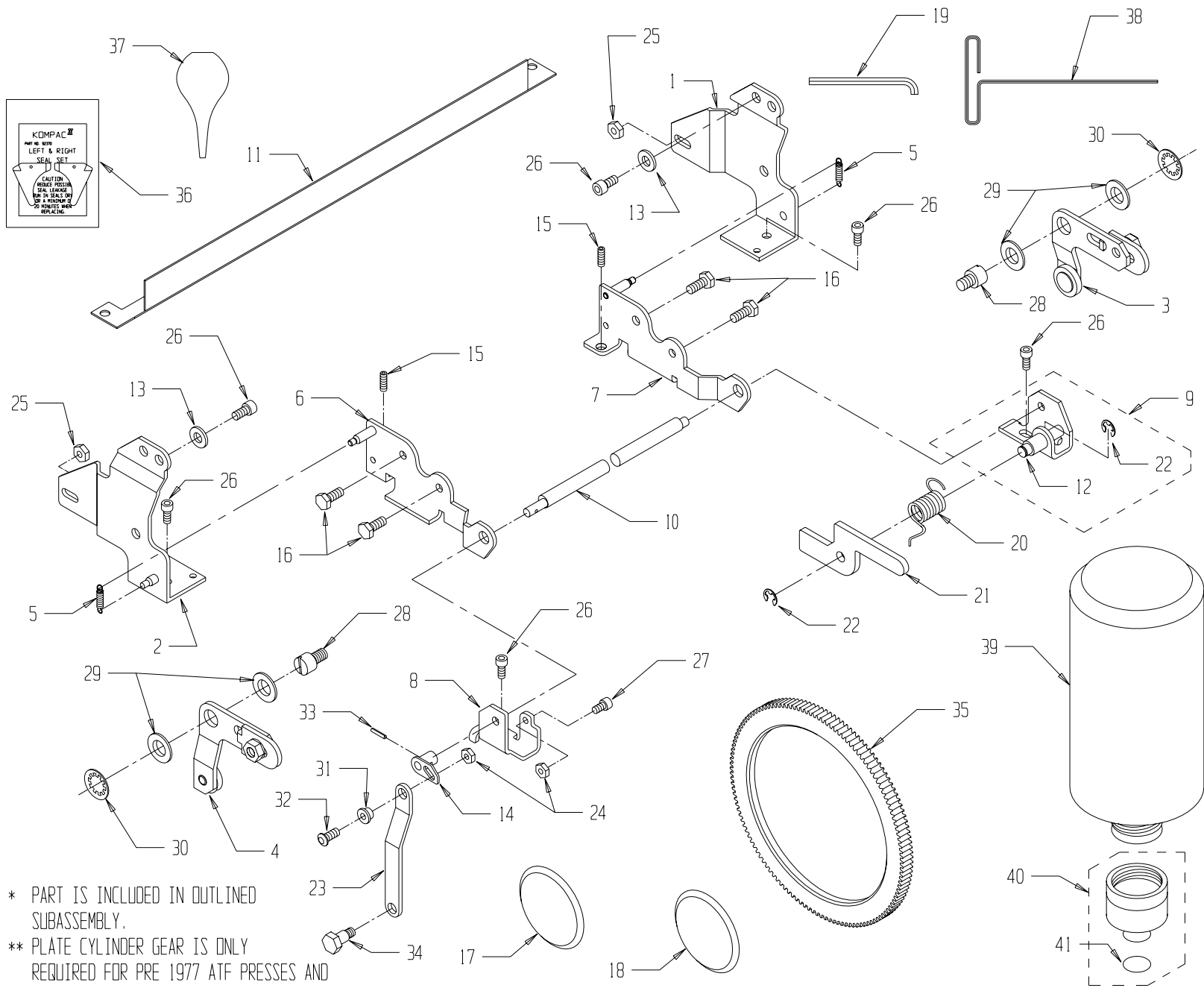

* PART IS INCLUDED IN OUTLINED SUBASSEMBLY.
 ** PLATE CYLINDER GEAR IS ONLY REQUIRED FOR PRE 1977 ATF PRESSES AND IS NOT INCLUDED WITH BRACKET KIT (P/N 93720).

ITEM#	PART #	DESCRIPTION	QTY
41	92765	O-RING	*
40	92760	DISPENSING VALVE ASSY	1
39	92771	CALIBRATED BOTTLE	1
38	90755	3/32" T-WRENCH	1
37	92778	KOMPAC SYRINGE	1
36	92370	KOMPAC SEAL SET (L & R)	1
35	92855	PLATE CYLINDER GEAR	**
34	93752	LOCKOUT SHOULDER SCREW	1
33	91940	3/32 x 1/2 ROLL PIN	1
32	91819	10-24 x 1/2 BUTTON HEAD SCW	1
31	93754	ATF LOCKOUT BUSHING	1

30	91747	CIRCULAR PUSH-ON WASHER	2
29	91739	.442 x .750 WASHER	4
28	90934	THREADED STUD	2
27	91818	10-24x3/8 SOCKET HD CAP SCW	1
26	91875	1/4-20x3/8 SOCKET HD CAP SCW	6
25	91972	1/4-20 LOCK NUT	2
24	91968	10-24 LOCK NUT	1
23	93753	ATF LOCKOUT LINK	2
22	91994	5/16" E-RING	1*
21	93621	PLATE CLAMP PAWL	1
20	93626	PLATE CLAMP SPRING	1
19	93708	3/16" ALLEN WRENCH	1
18	93749	2" DIA. HOLE PLUG	1
17	93748	2-1/8" DIA. HOLE PLUG	1
16	91868	1/4-20 x 3/4 HEX HEAD SCREW	4

15	91850	10-32 x 1/2 SET SCREW	2
14	93710	ATF LEVER ASSY	1
13	91962	#12 WASHER	2
12	93623	PAWL SUPPORT BOLT	*
11	93707	PINCH GUARD	1
10	93751	ATF ECCENTRIC SHAFT	1
9	93686	R.H. PIVOT BRACKET ASSY	1
8	93685	L.H. PIVOT BRACKET ASSY	1
7	93758	R.H. MOUNTING BRACKET ASSY	1
6	93757	L.H. MOUNTING BRACKET ASSY	1
5	93553	EXTENSION SPRING	2
4	90930	OP-SIDE LIFT LINK ASSY	1
3	90940	NON-OP SIDE LIFT LINK ASSY	1
2	93687	L.H. INKER BRACKET	1
1	93688	R.H. INKER BRACKET	1