

Date of Installation : _____

Unit Serial Number : _____

Kompac Dealer : _____

Kompac®



A DIVISION OF DAY INTERNATIONAL, INC.



DAY INTERNATIONAL, INC.

Image Transfer Group

Kompac®



HMD 600-1

Parts Catalog # 092132

159 DWIGHT PLACE , FAIRFIELD , NEW JERSEY 07004

TEL: 973-227-8611 / 800-541-5702

FAX: 973-227-7532

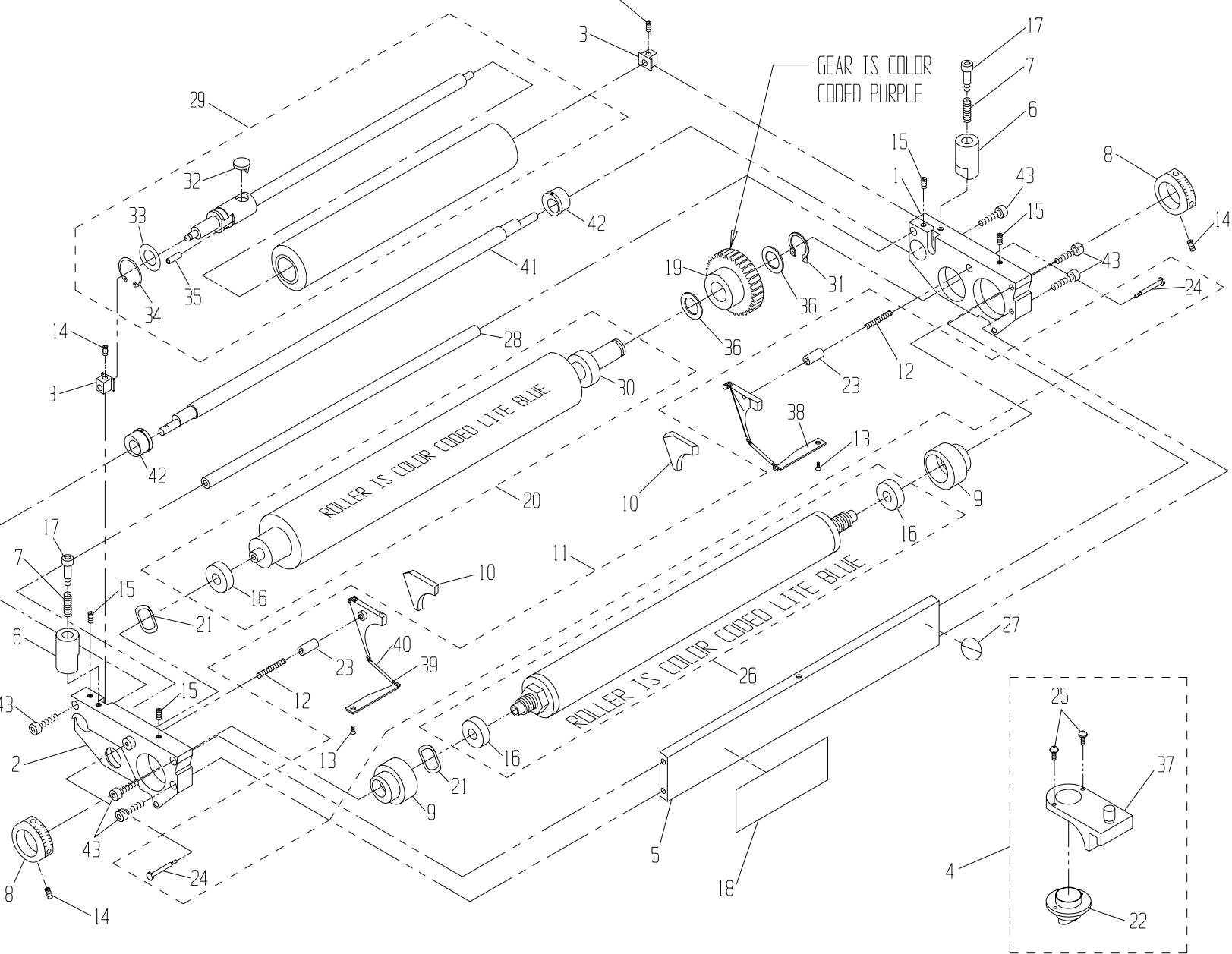

* PART IS INCLUDED IN OUTLINED SUBASSEMBLY.

43	091891	M5 x 16mm SOC. HD. SCREW	6
42	093103	ECCENTRIC	2
41	092143	SHAFT, ECCENTRIC	1
40	092259	SPRING COVER	*
39	092236	TAB SPRING	*
38	090971	TAB, SHORT	*
37	094997	BRACKET, NOZZLE	*
36	091966	WASHER, FLAT	2
35	091949	SPRING PIN	*
34	091997	OSC. RETAINING CLIP	*
33	091965	OSC. RETAINING WASHER	*
32	091111	OSC. DRIVE SHAFT FOLLOWER	*
31	091662	RETAINING RING	1
30	092586	BEARING	*
ITEM#	PART #	DESCRIPTION	QTY

29	091303	11-1/2 OSC. ROLL. PARTS ASSY	1
28	092138	TIE ROD	1
27	092601	SAFETY STICKER	1
26	092145	11 5/8" METERING ROLLER W/B	1
25	091907	#6-32 X 3/8 PHILLIPS HD SCW	*
24	092296	SHOULDER SCREW	*
23	092304	GUIDE PIN	*
22	092604	NOZZLE	*
21	092491	WAVE WASHER	2
20	092144	11 5/8" FORM ROLLER W/B	1
19	090969	GEAR CLUTCH ASSY	1
18	090984	I.D. STICKER (HAMADA)	1
17	091708	SHOULDER SCREW, 6mm	2
16	092401	BEARING	*
15	091904	M5 x 16mm SET SCREW	4
ITEM#	PART #	DESCRIPTION	QTY

14	091888	M5 X 5mm SET SCREW	4
13	091901	M3 x 6mm SOC HD SCREW	*
12	092238	COMPRESSION SPRING	*
11	090970	BACKING PLATE KIT (HAMADA)	1
10	092370	SEAL SET (L & R)	1
9	092291	ECCENTRIC	2
8	092612	METERING GAUGE	2
7	092007	SPRING, COMPRESSION	2
6	094991	OSCILLATOR POST	2
5	092137	TIE PLATE	1
4	098750	BRACKET NOZZLE ASSEMBLY	1
3	090985	ALIGNMENT BLOCK	2
2	093127	ASSY, END FRAME, L.H.	1
1	093128	ASSY, END FRAME, R.H.	1
ITEM#	PART #	DESCRIPTION	QTY

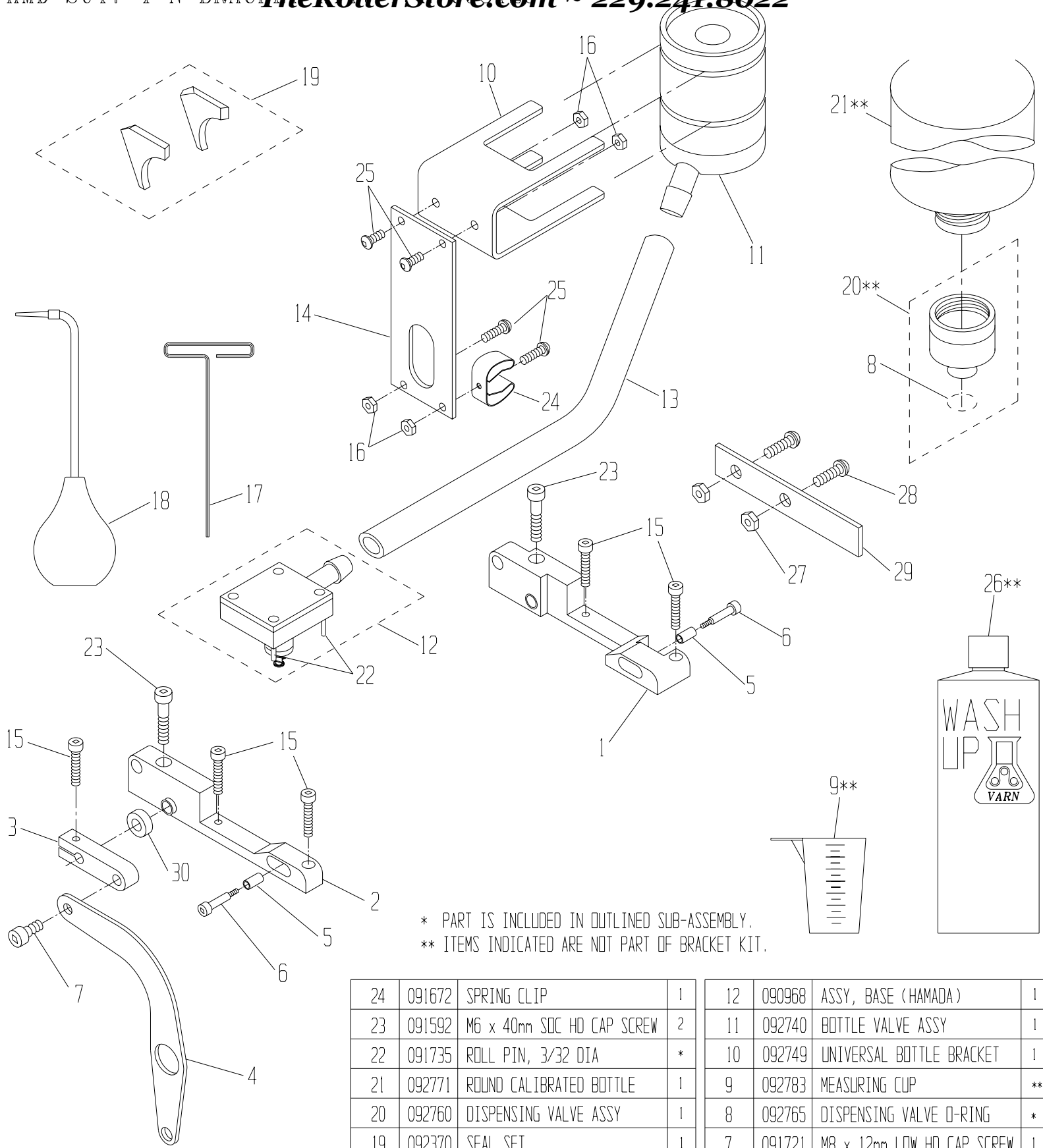

* PART IS INCLUDED IN OUTLINED SUB-ASSEMBLY.
 ** ITEMS INDICATED ARE NOT PART OF BRACKET KIT.

30	093178	COLLAR, SET SCREW, 8mm	1
29	093177	SUPPORT, HOSE	1
28	091766	M6 x 12mm BUT. HD. SCREW	2
27	091973	M6 LOCK NUT	2
26	092785	WASH-UP BOTTLE	**
25	091765	M5 x 12mm SCREW	4

24	091672	SPRING CLIP	1
23	091592	M6 x 40mm SDC HD CAP SCREW	2
22	091735	ROLL PIN, 3/32 DIA	*
21	092771	ROUND CALIBRATED BOTTLE	1
20	092760	DISPENSING VALVE ASSY	1
19	092370	SEAL SET	1
18	092779	SYRINGE, LONG NECK	1
17	090756	T-WRENCH, 2.5mm	1
16	091752	M5 NUT	4
15	091891	M5 x 16mm SCREW	5
14	092748	UNIVERSAL BRACKET	1
13	092756	1/2" VINYL TUBING	1

12	090968	ASSY, BASE (HAMADA)	1
11	092740	BOTTLE VALVE ASSY	1
10	092749	UNIVERSAL BOTTLE BRACKET	1
9	092783	MEASURING CUP	**
8	092765	DISPENSING VALVE O-RING	*
7	091721	M8 x 12mm LOW HD CAP SCREW	1
6	091712	SHOULDER SCREW M8 x 12mm	2
5	093111	SLEEVE (REWORKED)	2
4	093112	LIFT ARM	1
3	093107	ARM ON/OFF	1
2	093123	ASSY, MOUNTING BRKT, L.H.	1
1	093124	ASSY, MOUNTING BRKT, R.H.	1

ITEM#	PART #	DESCRIPTION	QTY
-------	--------	-------------	-----

ITEM#	PART #	DESCRIPTION	QTY
-------	--------	-------------	-----

ITEM#	PART #	DESCRIPTION	QTY
-------	--------	-------------	-----

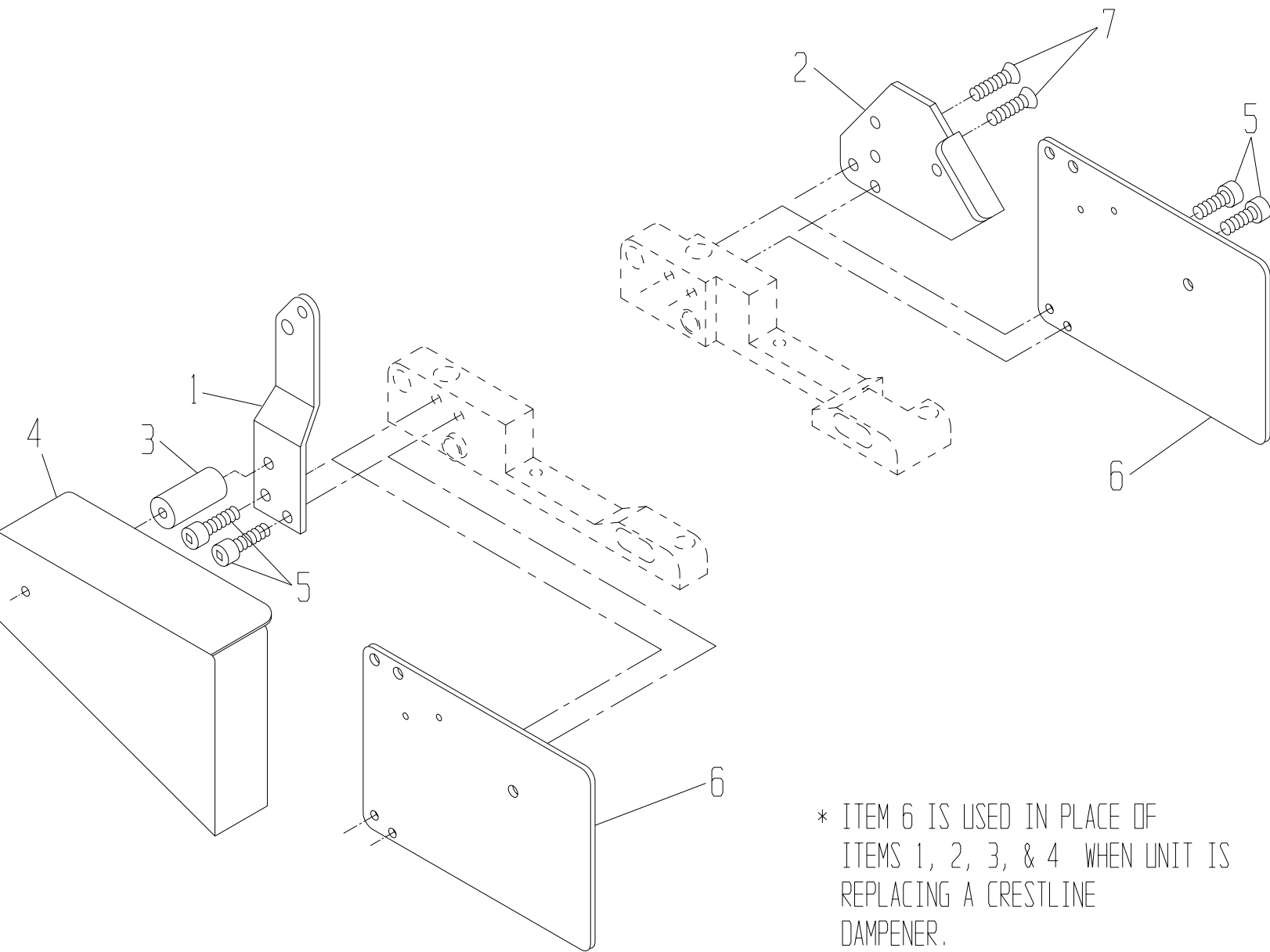

* ITEM 6 IS USED IN PLACE OF ITEMS 1, 2, 3, & 4 WHEN UNIT IS REPLACING A CRESTLINE DAMPENER.

7	091697	M5 x 16mm SCREW, FLAT HD	2
6	093139	MOUNTING BRKT, (CRESTLINE)	2
5	091757	M5 x 10mm SCREW, SOC HD	4
4	092139	GUARD, OP-SIDE, HMD-600-1	1
3	093655	STANDOFF, GUARD, OP-SIDE	1
2	092142	SUPPORT, GUARD, HMD 600-1	1
1	093136	SUPPORT, GUARD, OP-SIDE	1
ITEM#	PART #	DESCRIPTION	QTY