

Extra Roller Kit (XSA-XR3302)

Installation Instructions

Ryobi 3302

ACCEL  [®]
Graphic Systems

GENERAL INFORMATION

**ATTENTION
CRESTLINE®
OWNER!**

Accel Graphic Systems provides parts and service through its authorized distributors and dealers. Therefore, all requests for parts and service should be directed to your local dealer.

The philosophy of Accel Graphic Systems is to continually improve all of its products. Written notices of changes and improvements are sent to Accel Graphic Systems' Dealers.

If the operating characteristics or the appearance of your product differs from those described in this manual, please contact your local Accel Graphic Systems Dealer for updated information and assistance.

Always update your equipment when improvements are made available, especially those related to safety.

YOUR AUTHORIZED CRESTLINE® DEALER IS:

For technical assistance, please contact:

ACCEL GRAPHIC SYSTEMS
11103 Indian Trail
Dallas, TX 75229
PHONE (972) 484-6808
FAX (800) 365-6510
E-MAIL accel@dallas.net
WEB SITE www.accelgraphicsystems.com

Crestline® is covered by U.S. Patents and Patents Pending

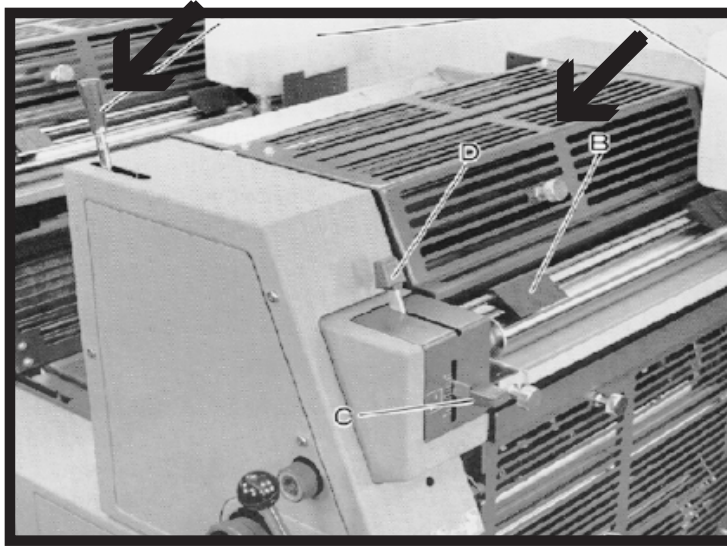

RYOBI 3302 RIDER ROLL

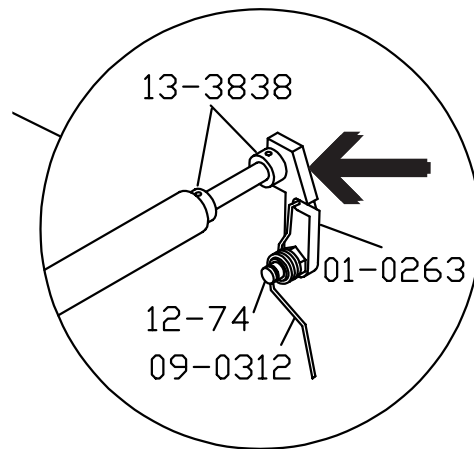
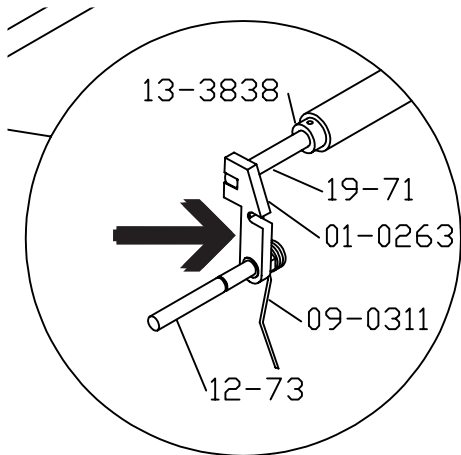
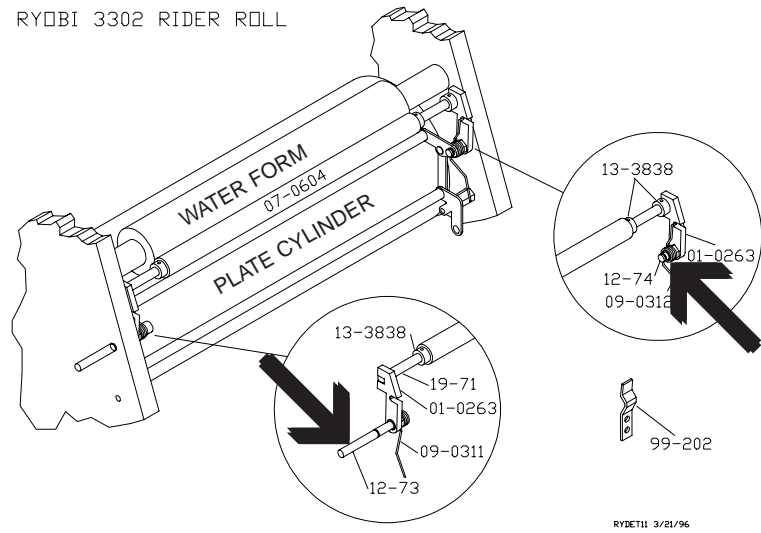



1

At OPS & NOPS, remove the upper covers from the press on both units.

2

At OPS & NOPS, remove the safety bar studs. The OPS activates a safety switch. You must remove the cam on the end and install it on the new stud provided.

3

When installing the new studs, be sure to slip the hangers on before reassembling.

5

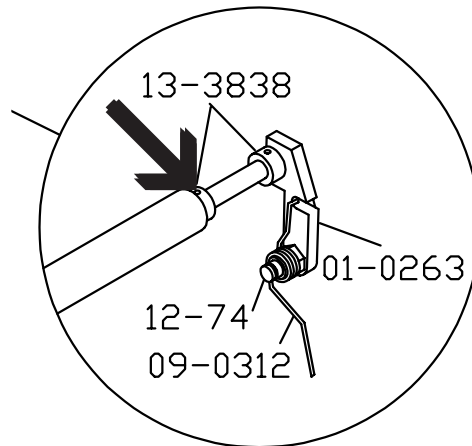
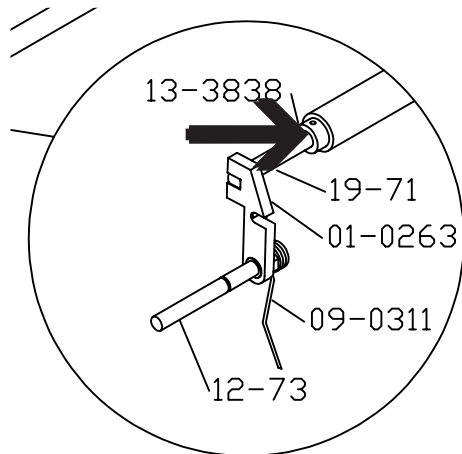
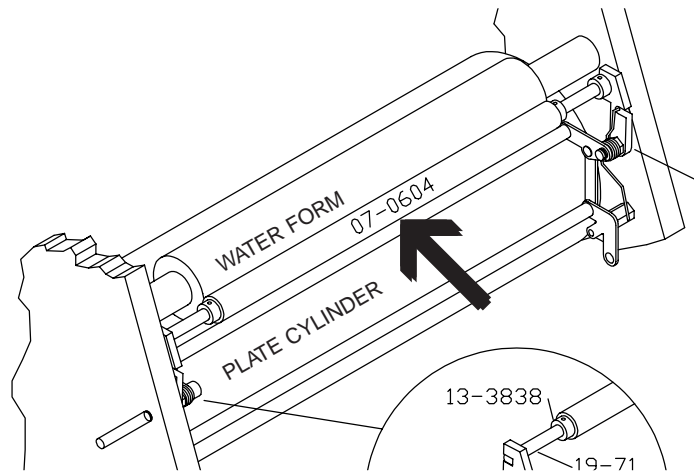
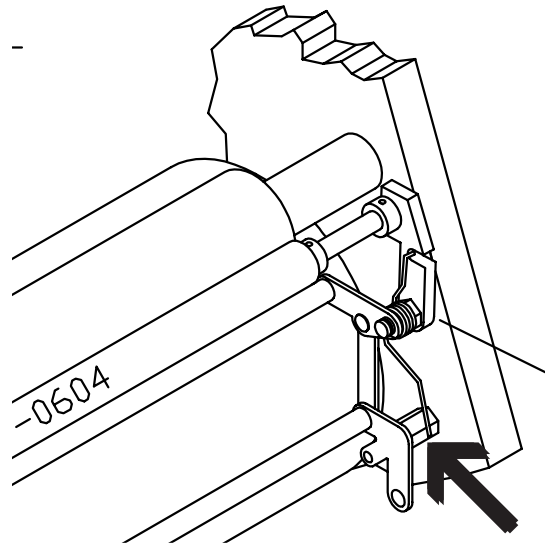

4

Install the springs as shown. The lower leg of the spring should rest against the stud shown below.

5

Once the brackets are installed, pivot the brackets back and place the roller in the slots. Pivot the roller up against the form and place the springs in the spring slot.

6

Check the roller to be sure it is centered to the form. Adjust if necessary. Remove any end play in the roller by sliding the collar over against the hanger.

7

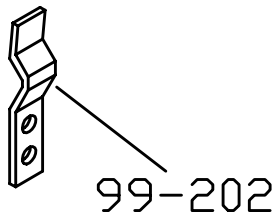

7

Check the stripe from the form roller to the extra roller. It should be approximately 1/8" (3mm). If the stripe is too strong, then you must re-tension the spring to obtain the proper stripe.

8

On the second head you must install the bracket provided. This will space the guard out slightly for proper clearance.

9

On the first head you must adjust the magnets on the tie bar so they are as far forward as possible to insure proper clearance.

9

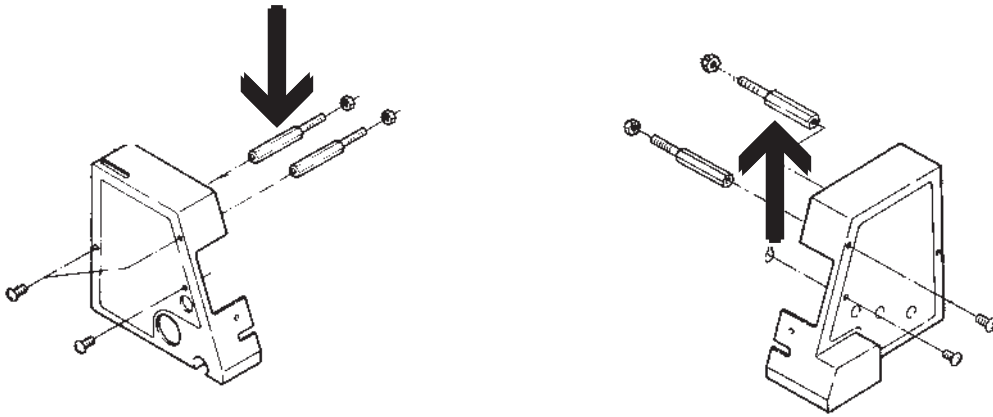

10

If the covers are mounted and the covers extend past the inside frame of the press, then the hangers will not fully pivot. It may be necessary to adjust the cover mounting studs out for clearance.

11

RYOBI 3302 RIDER ROLL

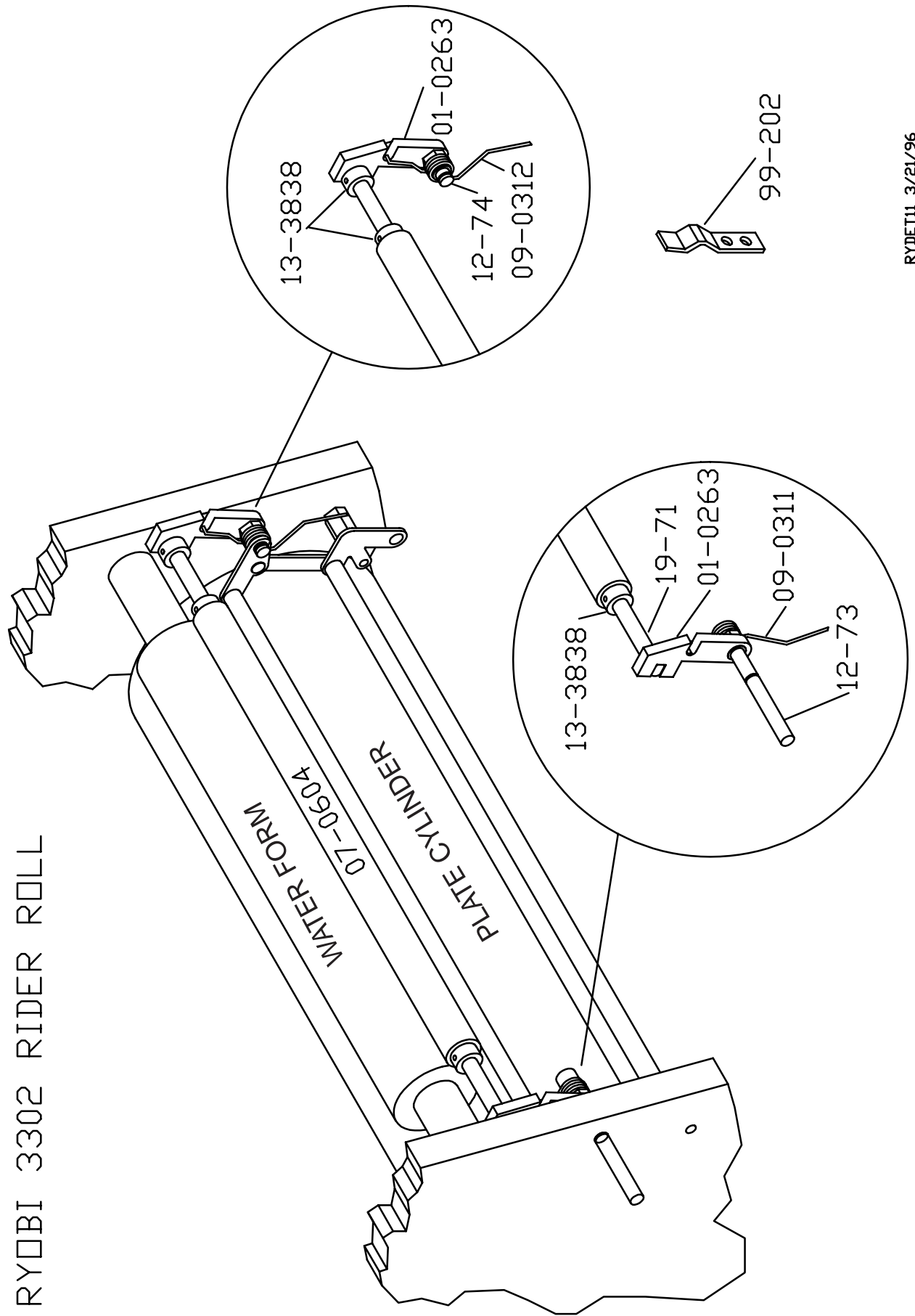

ACCEL  [®]
Graphic Systems

11103 Indian Trail, Dallas, TX 75229 Phone 972-484-6808, Fax 800-365-6510
E-mail accel@dallas.net, Web Site www.accelgraphicsystems.com