

Tempest[®] Hot Air Drying System

Installation Instructions

Hamada C248/C252

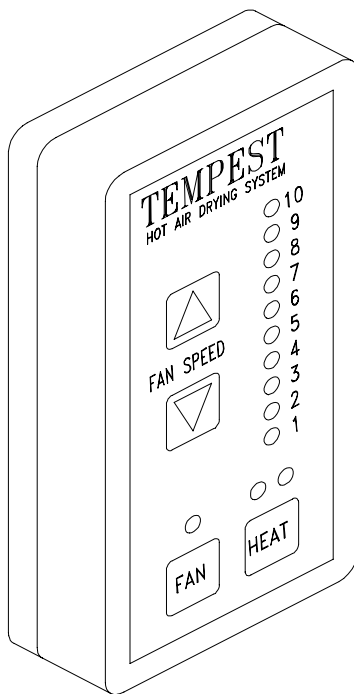

ACCEL  [®]
Graphic Systems

GENERAL INFORMATION

ATTENTION TEMPEST® DRYER OWNER!

Accel Graphic Systems provides parts and service through its authorized distributors and dealers. Therefore, all requests for parts and service should be directed to your local dealer.

The philosophy of Accel Graphic Systems is to continually improve all of its products. Written notices of changes and improvements are sent to Accel Graphic Systems' Dealers.

If the operating characteristics or the appearance of your product differs from those described in this manual, please contact your local Accel Graphic Systems Dealer for updated information and assistance.

Always update your equipment when improvements are made available, especially those related to safety.

YOUR AUTHORIZED TEMPEST® DEALER IS:

THE SERIAL NUMBER OF YOUR TEMPEST® HOT AIR DRYING SYSTEM IS:

CONTROL BOX _____

FAN UNIT _____

TECHNICAL ASSISTANCE

For technical assistance during the installation, please contact:

ACCEL GRAPHIC SYSTEMS
11103 Indian Trail
Dallas, TX 75229
PHONE (972) 484-6808
FAX (800) 365-6510
E-MAIL accel@dallas.net
WEB SITE www.accelgraphicsystems.com

GENERAL INFORMATION

ELECTRICAL REQUIREMENTS

220 VAC 50/60 HZ
20 AMP DEDICATED LINE
NEMA L620R RECEPTACLE

IMPORTANT INFORMATION

The use of heat to accelerate drying may require more frequent lubrication and/or use of a high temperature lubricant in the delivery of the press. Please consult your press manufacturer for specific recommendations.

SAFETY INFORMATION

The Tempest® Dryer contains high voltage and hot surfaces. Never attempt to service or work on the unit unless the power is shut off and the unit is cool.

Visually inspect the thermistors (triangle-shaped objects arranged in a honeycombed pattern on the underside of the unit) weekly. If a thermistor is damaged or cracked, do not operate the dryer. Contact Accel immediately for a replacement part.

The fans should be turned on and set at the lowest speed ("0" on the dial) when running spray powder only without heat. This prevents spray powder from accumulating in the thermistors and housings.

TERMINOLOGY

OPS = Operator's Side
NOPS = Non Operator's Side

GENERAL INFORMATION

HOT AIR VS INFRARED: WHAT MAKES TEMPEST® WORK

Although the technology behind the Tempest® dryer was significant enough to be awarded the GATF Intertech Award, it is by no means new. In fact, thermistors have been in use for many years. They were originally used in motors and other devices as a heat controller and later used in refrigeration to turn compressors on and off. It is only in the last 10 years or so that thermistors have been used as a heater.

Heat is generated by the thermistor because of the difficulty of electricity travelling through it when it is a conductor. The thermistor acts as a conductor until it reaches its set temperature and then it becomes a resistor. A thermistor is basically a coated semiconductor designed to switch from a conductor to a resistor at an established temperature.

When a current is applied to the thermistor it initially uses a large amount of electricity and heats up very quickly until it reaches its maximum set temperature. At this point it should not use any more electricity. However, air that is passed through the holes in the thermistor causes it to cool. This activates the thermistor to start using more power again so it can get back to its set temperature. The thermistor is constantly regenerating itself to stay at a constant temperature. This process is called autostabilization.

Thermistors are also the key element that makes the Tempest® dryer safe. Because the set temperature of the thermistor is lower than the flash point of paper, you can place even the most easily burned substrate (such as tissue paper) on top of the thermistor element without causing a fire. The tissue won't even char, let alone ignite. If you were to do the same with an IR element, a fire could start in a matter of seconds. This is particularly important if a jam occurs in the delivery.

The objective of any drying system is to raise the pile temperature to accelerate the drying of the ink. However, heating the paper too much can aggravate problems such as blocking, setoff, mottle, loss of gloss, and loss of halftone definition. Too much heat can also cause the paper to shrink which can cause register problems in multiple pass work. The Tempest® dryer can keep the pile at a lower temperature than IR and still effectively set the ink film.

GENERAL INFORMATION

IR dryers use very high temperatures and a fixed amount of electricity. The heat generated from an IR dryer can cause premature wear of press parts. Because the thermistors used in the Tempest® dryer use lower temperatures the chance of premature wear is reduced.

HOW DRYING IS ACCOMPLISHED WITH TEMPEST®

Tempest® "sets" the surface of the ink to prevent set-off from one sheet to another and to minimize the use of powder.

Tempest® accelerates the final drying of oil based inks by raising the temperature of the delivery stack.

KEY FACTORS TO REMEMBER ABOUT DRYERS FOR SMALL OFFSET PRESSES.

Do not expect a dryer to "instantly" dry the ink. Only UV inks and coating dry instantly. The technology and hazards of such systems make them cost prohibitive on small offset presses.

Some jobs may require spray powder. Because dryers for small offset presses do not dry ink instantly, powder will be required from time to time. However, you should expect to see a significant decrease in the amount of powder needed on a regular basis.

Drying time is dependent upon press speed, paper stock, ink coverage, type of ink, etc.

Do not expect a dryer to accelerate the drying of rubber based inks. These inks dry by absorption into the stock, and heat does not accelerate this process.

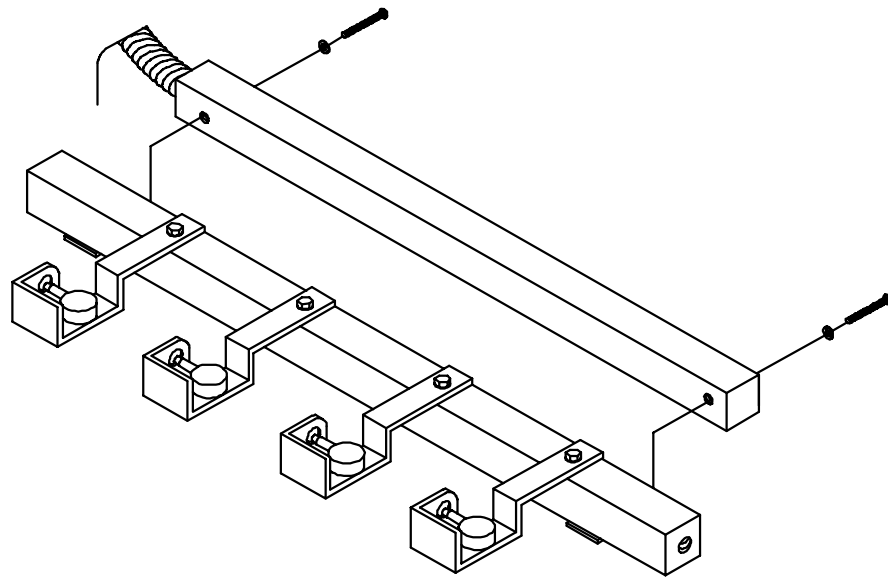
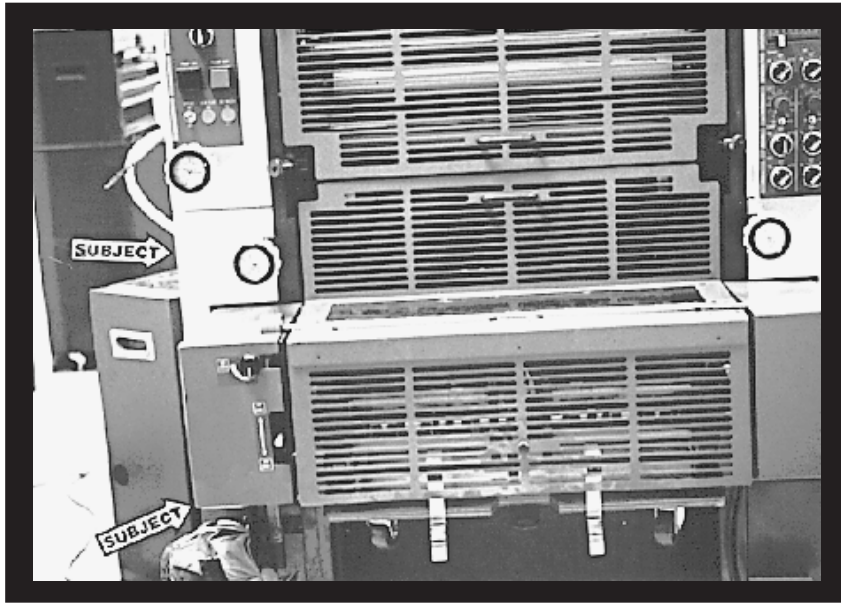

INSTALLATION

1

Disconnect the electrical power to the press.

Remove the upper and lower OPS and NOPS covers.

2

Remove the static eliminator from the tie bar in the delivery. Disconnect the hoses from the factory spray nozzles. Remove the tie bar from the delivery. The static eliminator will be reattached in a later step. Save the tie bar bolts for reinstallation in a later step.

3

Remove OPS and NOPS delivery pile lift retaining studs. This stud is next to the pile lift chain sprocket in the delivery. Save the studs for reinstallation.

7

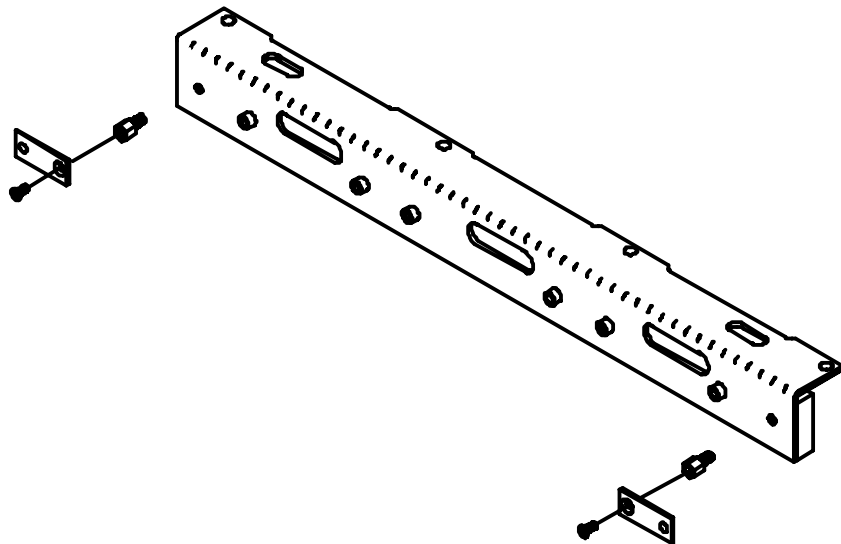
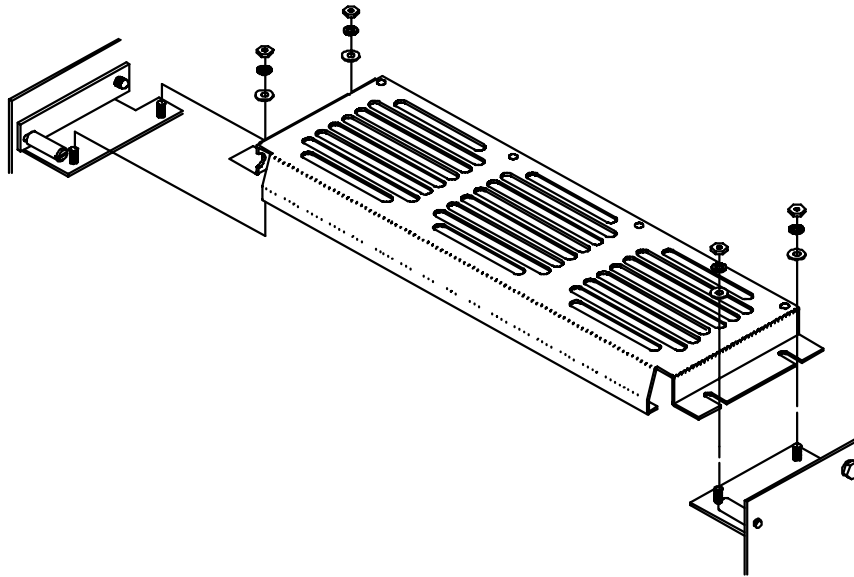
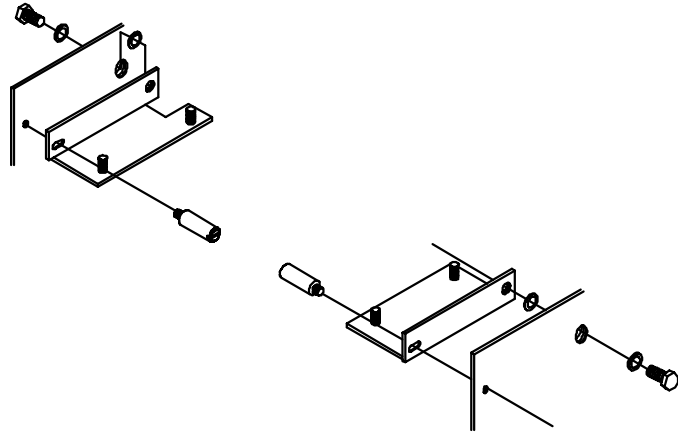

INSTALLATION

4

Install the Tempest® mounting brackets using the original tie bar mounting bolts and lift retaining studs. Since the mounting brackets straddle the area that the delivery frame meets the press frame casting it may be necessary to use the provided washers (05-302) between the press frame and bracket to create a flush mounting surface for the bracket.

NOTE:

Sometimes a bolt may be protruding through the press frame preventing the bracket from fitting flush against the frame. Should this be the case use the provided flat washers to prevent the bolt(s) from protruding past the inside of the frame.

5

Set the Tempest® unit on the mounting brackets with the cable exiting the dryer on the NOPS. Route the cable through the hole in the press frame. Center dryer and fasten to the mounting brackets with the hardware provided. With someone slowly rotating the press by hand, make sure the dryer is clear of all moving parts.

6

This step is only for presses also being equipped with the PowderPro®, otherwise skip to step 7.

Remove the threaded stand-offs (and extension brackets if a C252) from the spray bar included with the Tempest® and install on the PowderPro® spray bar assembly as shown in the diagram.

9

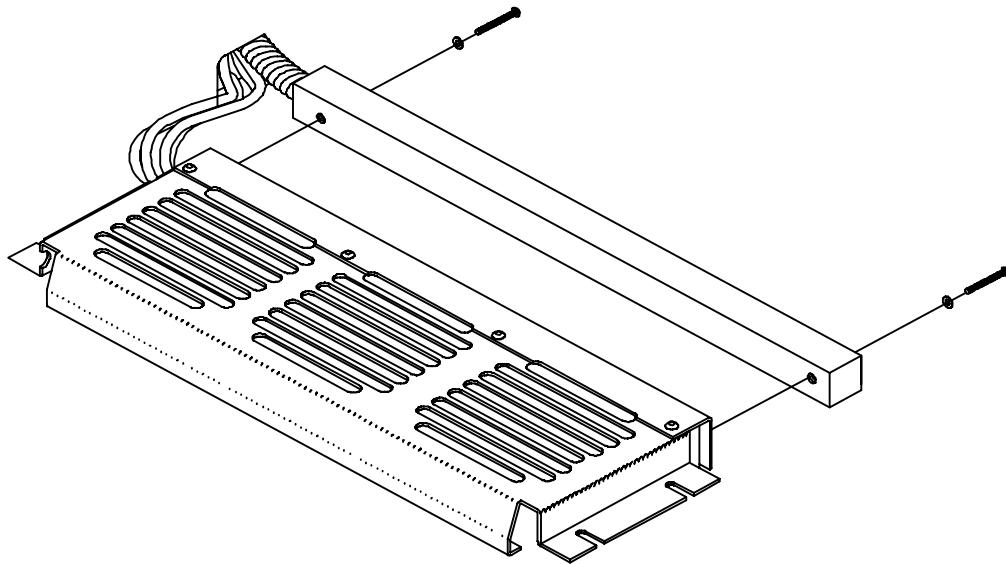
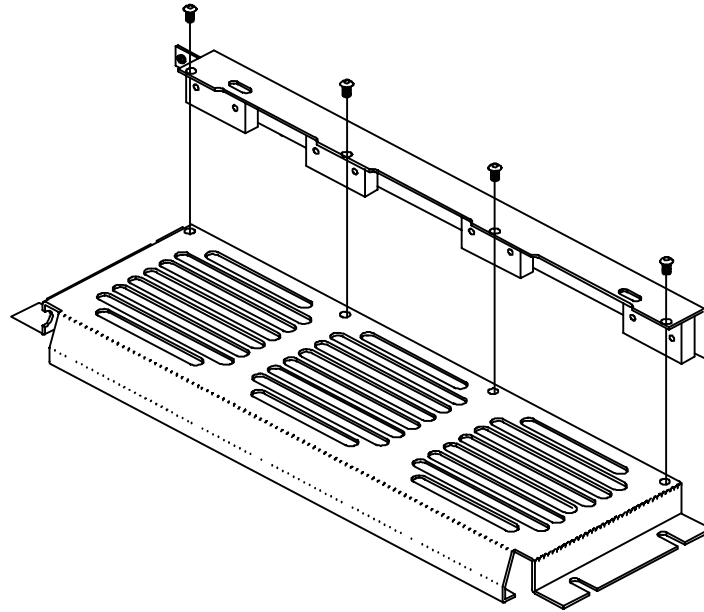

INSTALLATION

7

Using the supplied hardware attach the spray bar assembly to the dryer unit as shown in the diagram. Route the hoses through the same hole in the press that the original hoses used.

8

Install the static bar to the spray bar using the original screws and lock washers. The static eliminator attaches to the standoffs on the spray bar for C248's, on C252 presses the static eliminator attaches to the extension bracket already attached to the stand-offs.

9

Cut the original powder spray hoses, leaving about 4" connected to the distribution manifold. Use the provided reducer connectors to connect the new hoses to the original hoses.

11

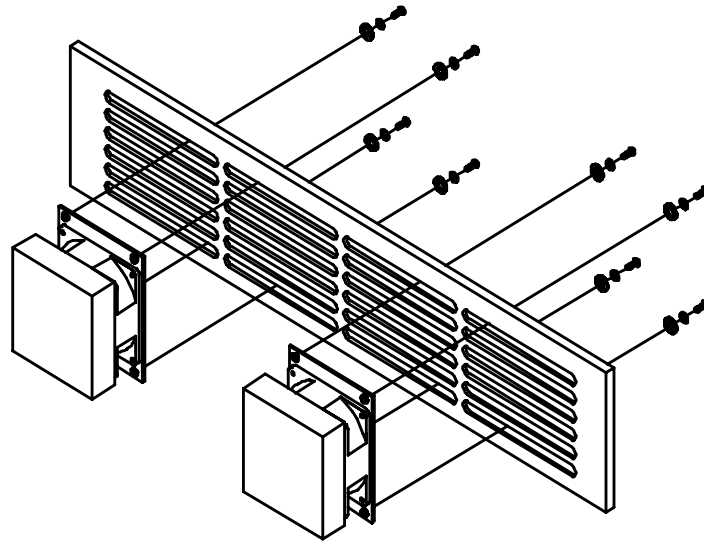
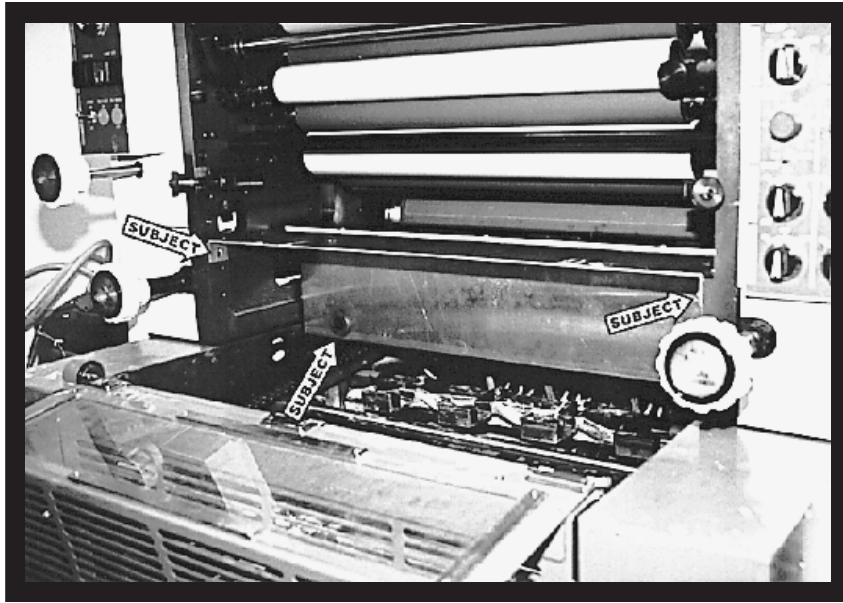

INSTALLATION

10

Pull the Tempest® cable out the opening in the bottom of the NOPS press side cover. Make sure that the cable clears all moving parts within the side cover, zip-tie as necessary.

11

Loosen the two side cover bolts (upper subject arrows) and install the shield in the press with the tabs (upper subject arrows) as shown. The hole (lower subject arrow) is for routing the hoses to the optional blanket washer.

12

Mount the exhaust fan assemblies to the outside of the guard in the end of the delivery as shown in the diagram.

13

INSTALLATION

13

Locate the CN11 connector on the circuit board in the press electrical cabinet. Attach the provided t-tap connectors to wire no.'s Y31 and T (no. 1 impression solenoid) and wire no.'s Y33 and T (no. 2 impression solenoid).

14

Find a suitable location for the main Tempest® electrical box on the NOPS of the press. Route the exhaust fan cable (two conductor) into the delivery and, using the provided closed end splice connectors, connect this cable to the exhaust fans installed in Step 12. Connect the red wire in the cable to the red fan wires and the black wire to the blue fan wires. Route the wires so that they do not interfere with the opening and closing of the guard. Use the provided cable clamps and stick on zip-tie mounts to secure the cable as necessary. Route the impression signal cable (four connector cable) into the press electrical cabinet. Connect the red and green wires in the cable to the T-tap connectors attached to wires Y31 and T, and the black and white wires in the cable to the T-tap connectors attached to wires Y33 and T.

Note: If the press is equipped with Accel's PowderPro® spray system, skip to step 17.

15

Remove the cover from the main Tempest® electrical box and insert the dryer cable through the strain relief on the bottom of the box. Remove the twelve position connector (only six positions are numbered) from the board and insert the wires into the connector by matching the numbered tags on the wires to the matching position on the connector. Secure the ground wire to the stud on the inside of the box. Replace the connector on the board and tighten the strain relief. Replace the cover on the box.

15

Diagram D

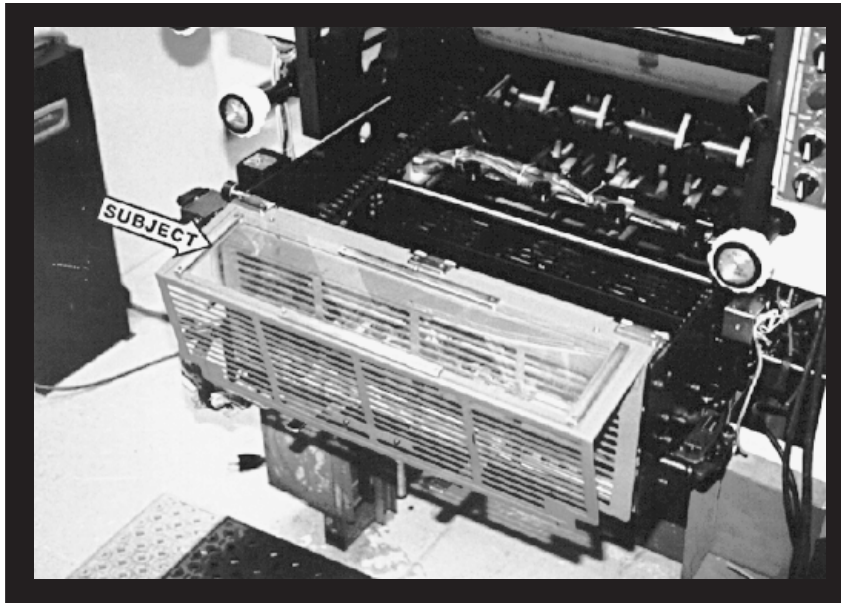
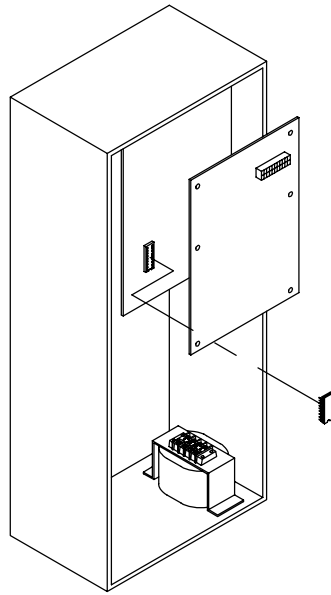

INSTALLATION

16

Note: This step is for presses that are equipped with the factory powder spray system. Skip this step if also installing PowderPro®. Remove the six Phillips head screws holding the printed circuit board. Carefully pull the board out far enough to remove the ROM chip from the board beneath it. Install the supplied replacement chip as shown in diagram D. Make sure that the chip is installed so that the notch coincides with the notch in the socket. Be careful not to damage any of the pins when inserting the chip. Replace the outer circuit board.
Note: If the press is an older style machine with the electrical cabinet under the delivery, there are two (2) ROM chips to replace. The replacement chips have the same corresponding numbers as the original ones.

17

Remove the plastic shield (subject arrow) from the delivery guard and replace it with the slotted metal shield supplied with Tempest®.

18

Reinstall the NOPS side cover to the press, routing the cable out of the cutout in the bottom of the cover.

Reinstall all remaining guards and covers. Rotate the press slowly by hand (or jog) to be sure that the dryer and its cables are clear of all moving parts.

17

OPERATION & MAINTENANCE

HOW DRYING IS ACCELERATED WITH TEMPEST®

Tempest® creates a two-step drying process when used with oil-based inks:

1. Skinning the surface of the ink with hot air to prevent set-off .
2. Accelerating the final drying process approximately 20° F over the cold stack temperature in the feeder. Heat accelerates the drying process, called oxidation and reduction, of oil-based inks.

In general, dryers (including infrared) do not work well with rubber or acrylic-based inks. These inks should be avoided when maximum results are desired.

HOW TEMPEST® WORKS

1. When voltage is applied to the thermistors (triangle-shaped coated semiconductors arranged in a honeycomb pattern), they begin to heat.
2. Thermistors heat to a predetermined temperature, in this case about 400° F, and remain at that temperature. This is known as autostabilization.
3. The fans blow air down towards and through the thermistors, creating a flow of hot air to the sheet.
4. Drying of the ink occurs in the two-step process as described above.

No dryer totally eliminates the need for spray powder. There may be some jobs (for example, a heavy solid on a high gloss sheet) where powder is required. Overall, Tempest® should reduce your spray powder usage significantly, giving you a better printed product and a cleaner working environment.

OPERATION & MAINTENANCE

TEMPEST® OPERATION

NORMAL OPERATION

Pressing the HEAT switch will illuminate both the green and yellow LEDs on the remote control unit. The green LED indicates that the fans (both dryer and exhaust fans if so equipped) are running while the yellow LED indicates that the dryer is armed and the heat will come on automatically when the press goes on impression. When the press does go on impression, the red LED will illuminate indicating that the heat is on. Pressing the heat button again will disarm the heat mode but the fans will continue to run. To turn the unit OFF press the FAN switch at any time.

FAN ONLY OPERATION

To operate only the fans, press the FAN switch. The green LED will illuminate and the fans will come on (both the dryer and exhaust fans if so equipped). The heat mode of the dryer is not armed and will not come on with impression. To turn the fans OFF press the FAN switch again.

FAN SPEED CONTROL

To adjust the fan to a higher setting, press the up arrow on the remote control unit. To decrease the fan speed press the down arrow on the remote. The fans will automatically go to the minimum speed setting for a few seconds when the press goes on impression and then they return to the previous setting. This reduction in fan speed allows the dryer to heat up more quickly.

INITIAL SETTINGS

Try running Tempest® with the fan speed at "4" with the switch on "HEAT." After about 1" of paper is stacked in the delivery, insert the thermometer into the center of the stack. Allow the thermometer to stabilize. It should be approximately 20° F above the initial pile temperature for optimum drying.

If the temperature is below that, **decrease the fan speed** slightly.

If the temperature is above that, **increase the fan speed** slightly.

OPERATION & MAINTENANCE

FACTORS THAT EFFECT DRYING

1. Press speed.
2. Amount of ink coverage and color.
3. Type of stock being printed.
4. Initial temperature of paper.

In time and with practice you will learn which settings are best for your particular shop.

KEYS TO REMEMBER

1. The Tempest® takes about 12 sheets to come up to full power. The dryer remains on as long as paper is being fed. It does not cycle like an IR dryer.
2. The pile temperature should be approximately 20° F above the initial pile temperature for optimum drying.
3. Use spray powder only when absolutely necessary. A little spray powder goes a long way. Use it sparingly.
4. Inspect the Tempest® weekly.

MAINTENANCE

1. Inspect the dryer weekly. If the thermistors are cracked or have been damaged, do not operate the dryer. Call Accel immediately.
2. Never squirt cleaning solvents, water, or any other liquids into the dryer. This may damage electrical components.
3. Any spray powder that accumulates in the dryer should be vacuumed out, not blown out.
4. Make sure all heat shields and guards are in place before operating the dryer or printing press.

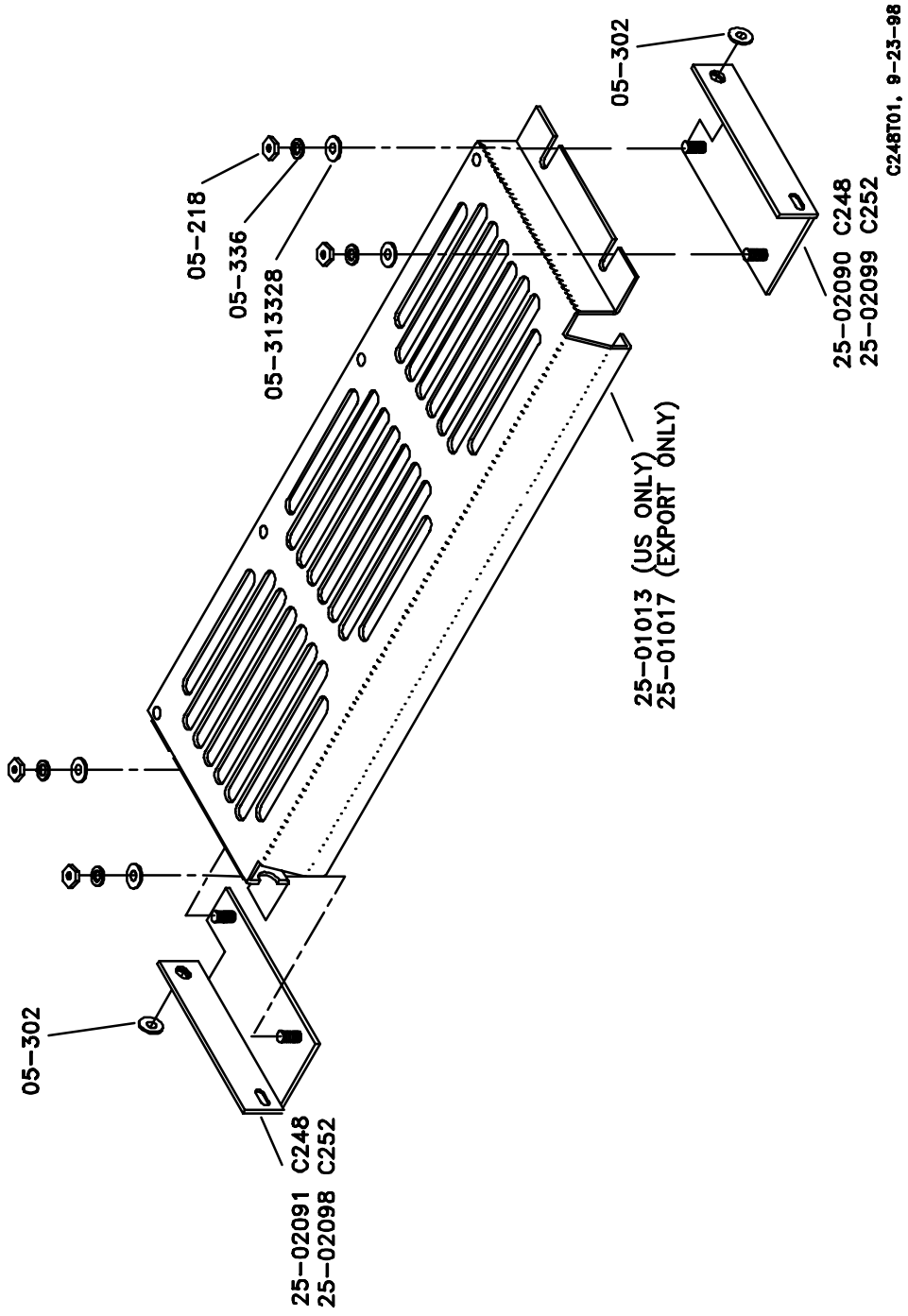

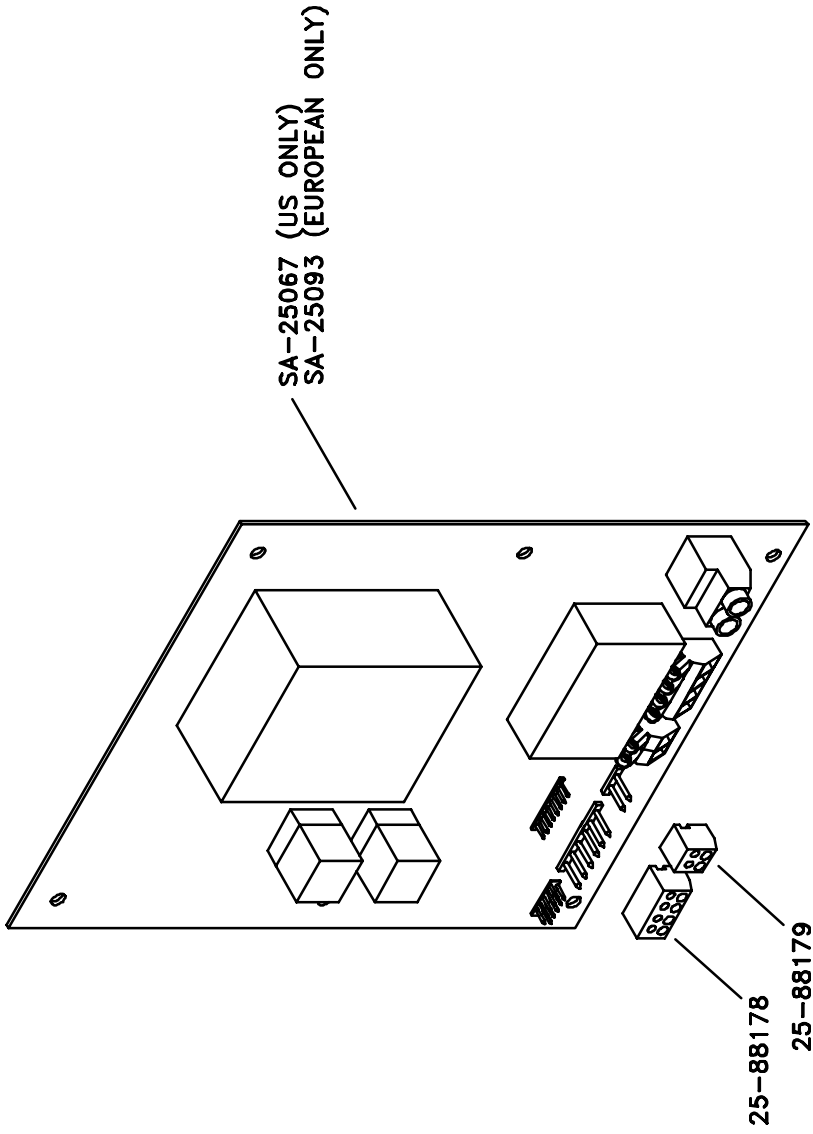

C248T02, 7/21/98

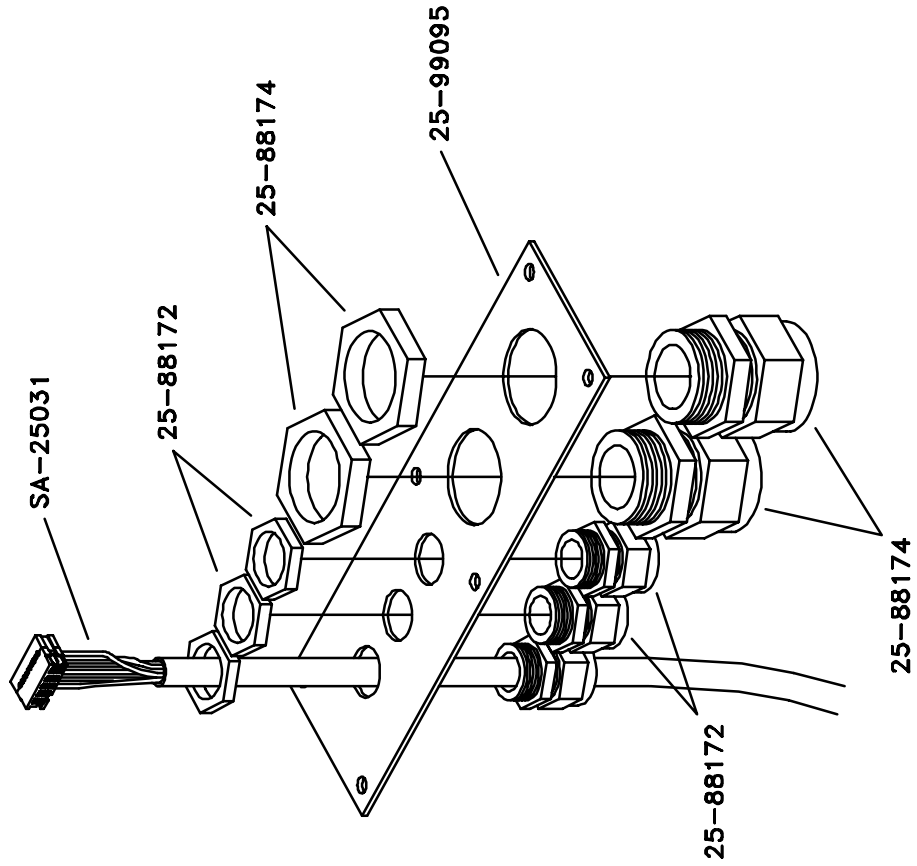

C248T03, 7/21/98

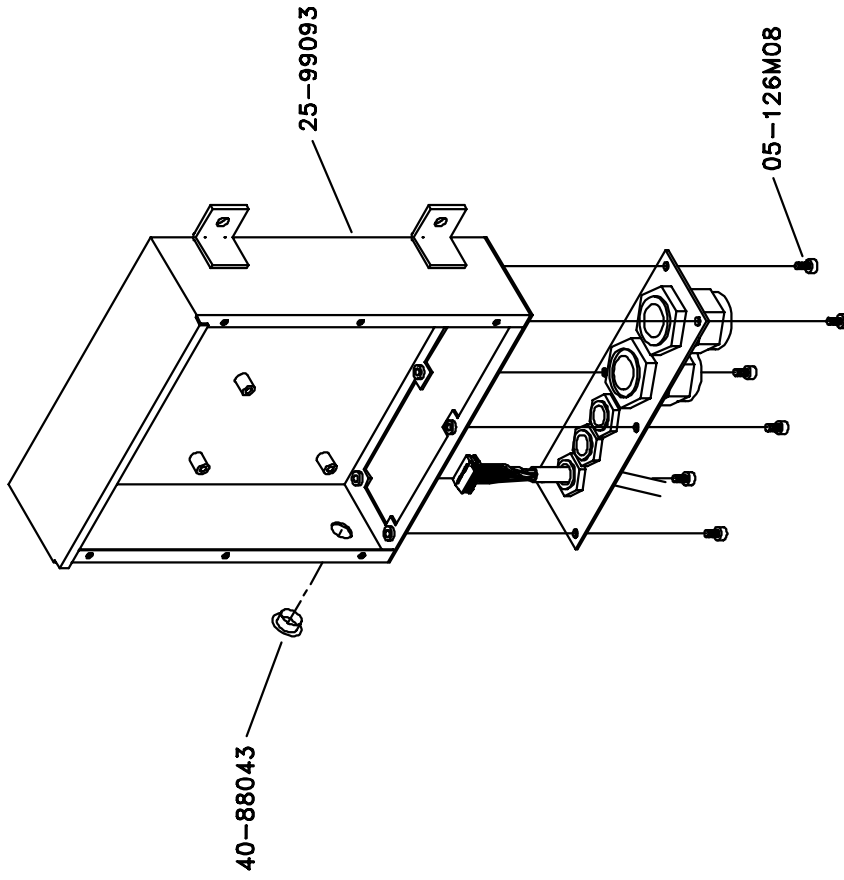

C248T04, 7/21/98

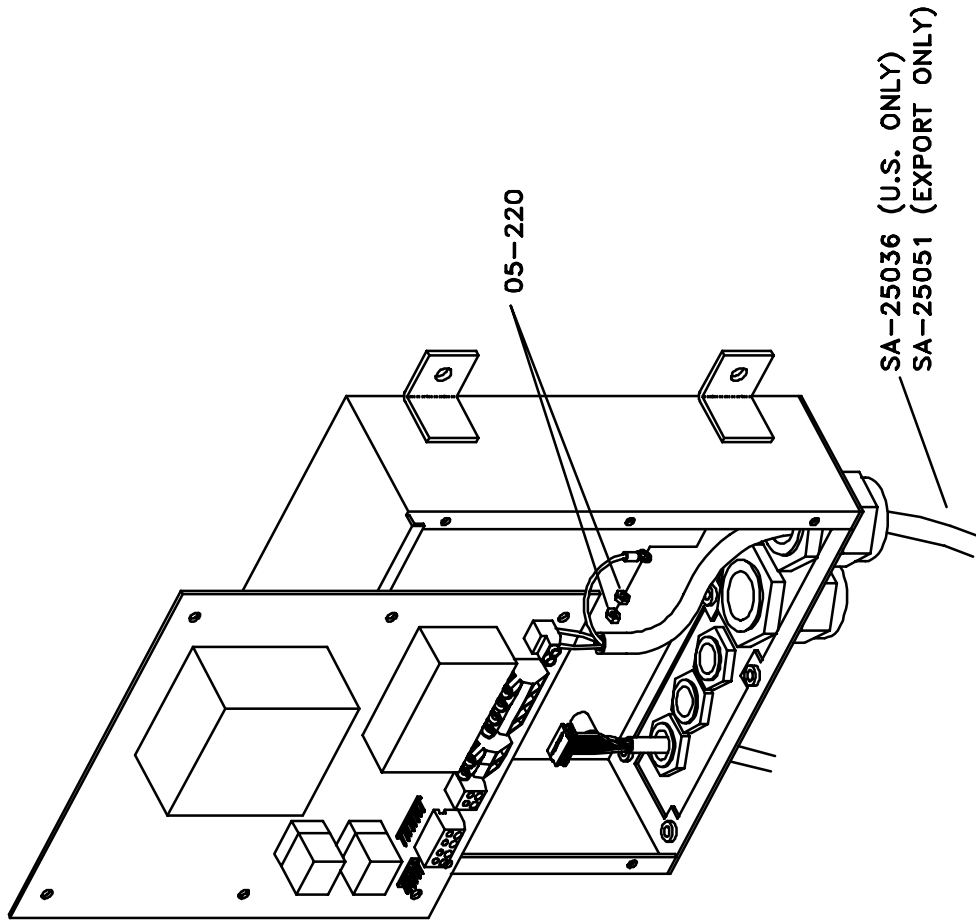

C246T05, 7/21/98

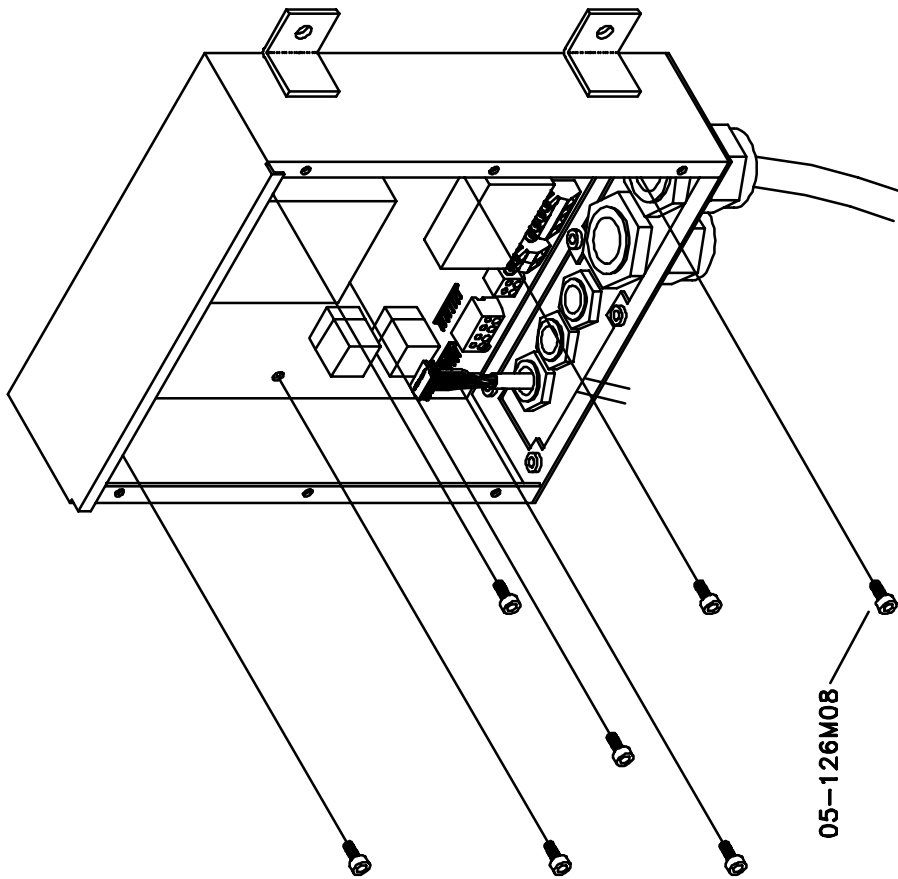

C245T07, 7/21/98

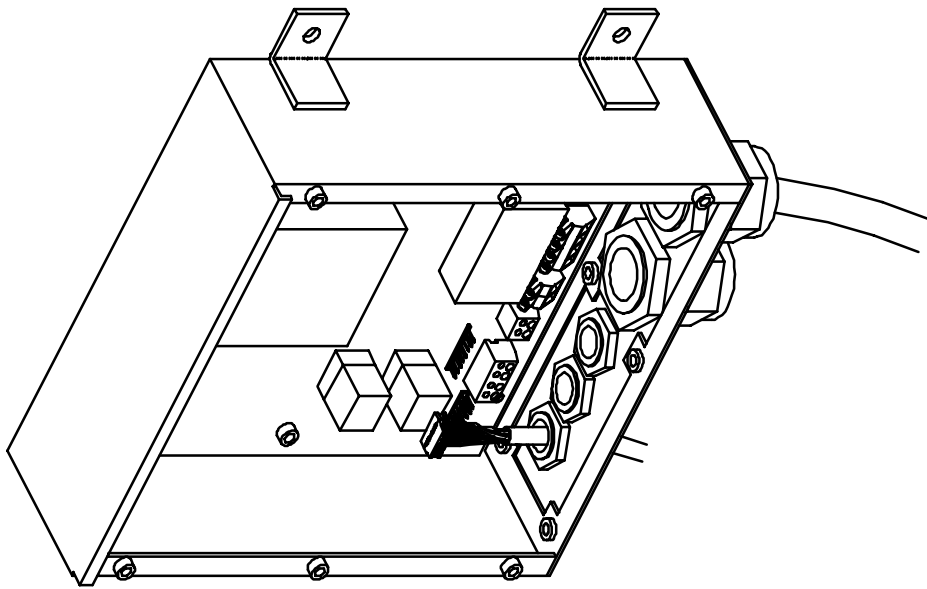

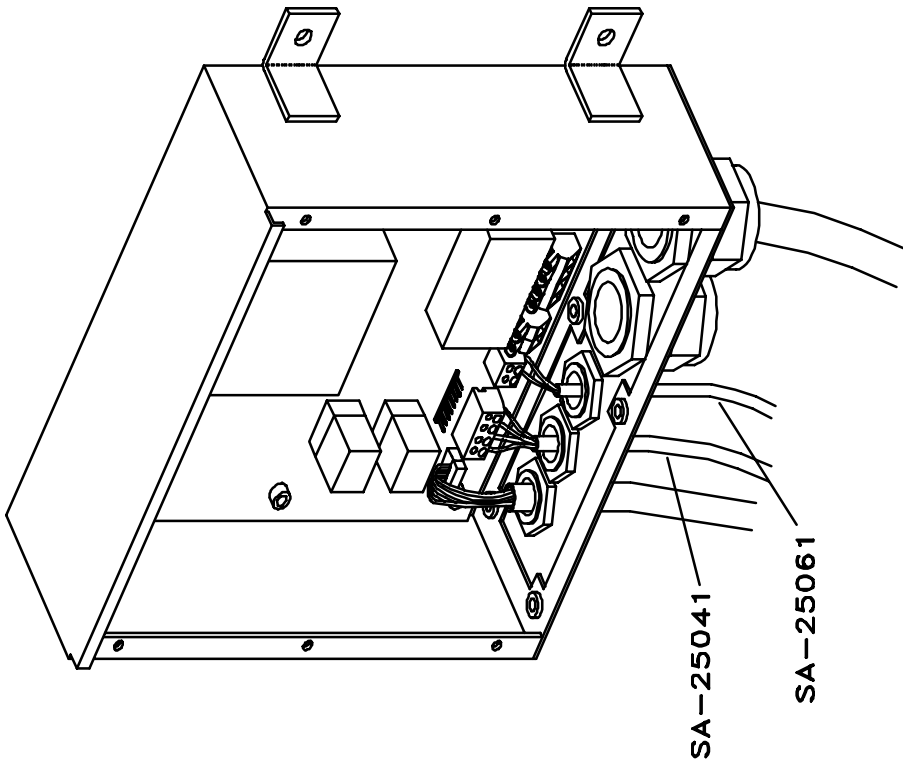

C248T08, 7/21/98

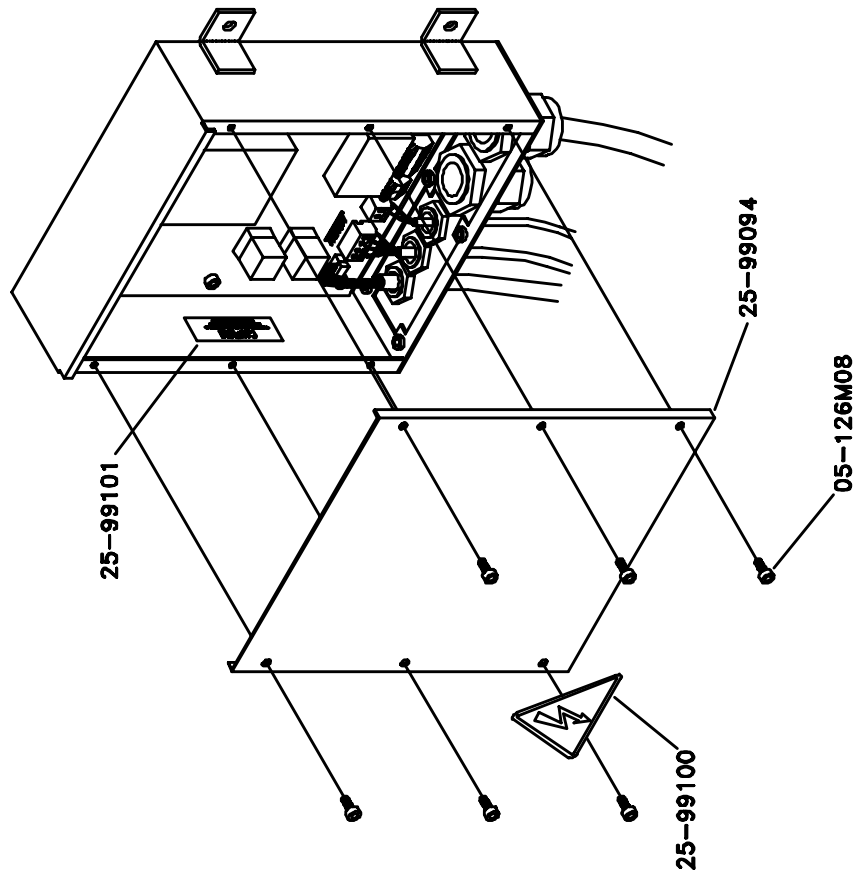

C248T09, 7/21/98

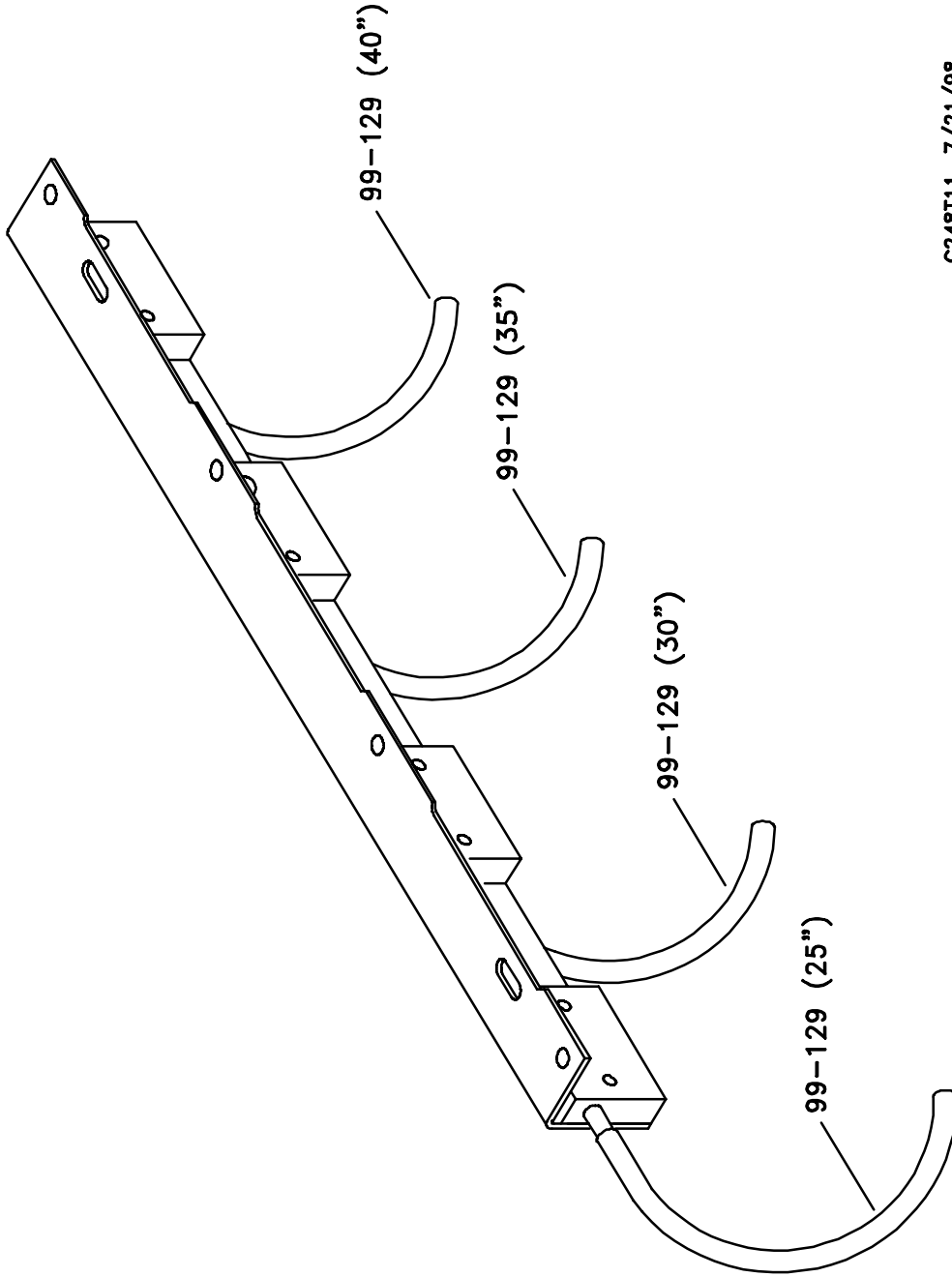

C248T11, 7/21/98

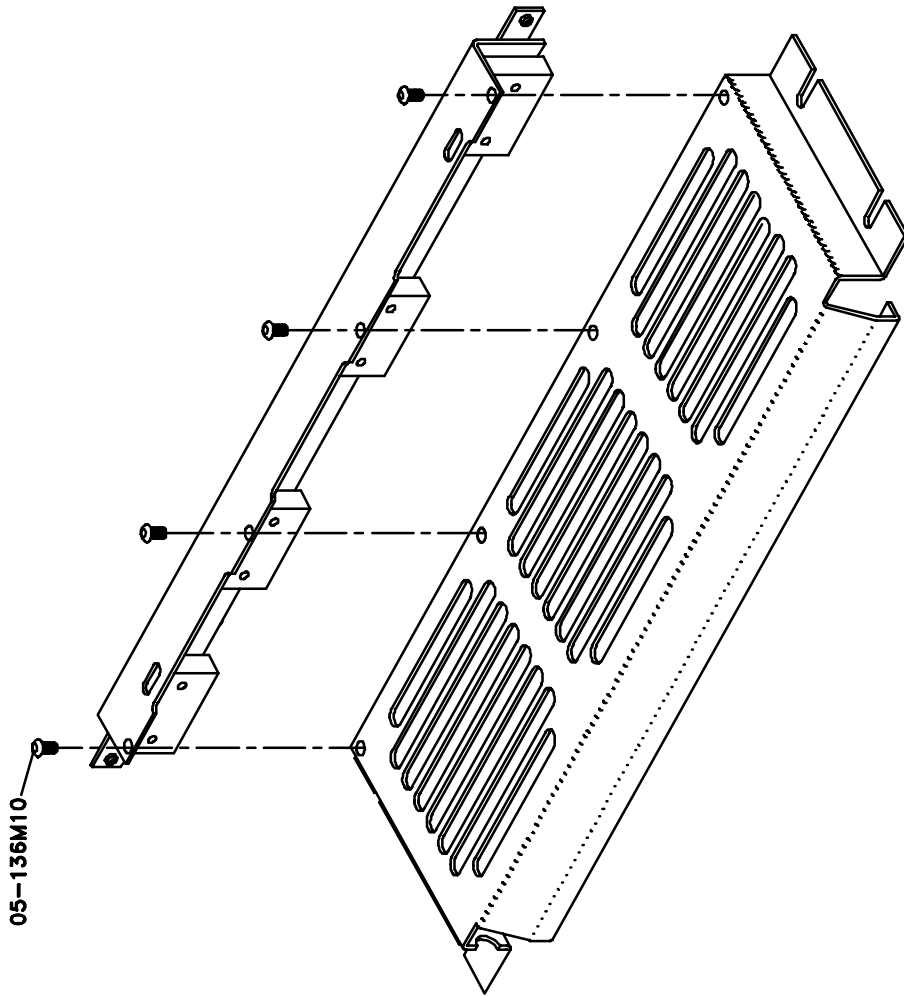

C248T12, 06-01-98

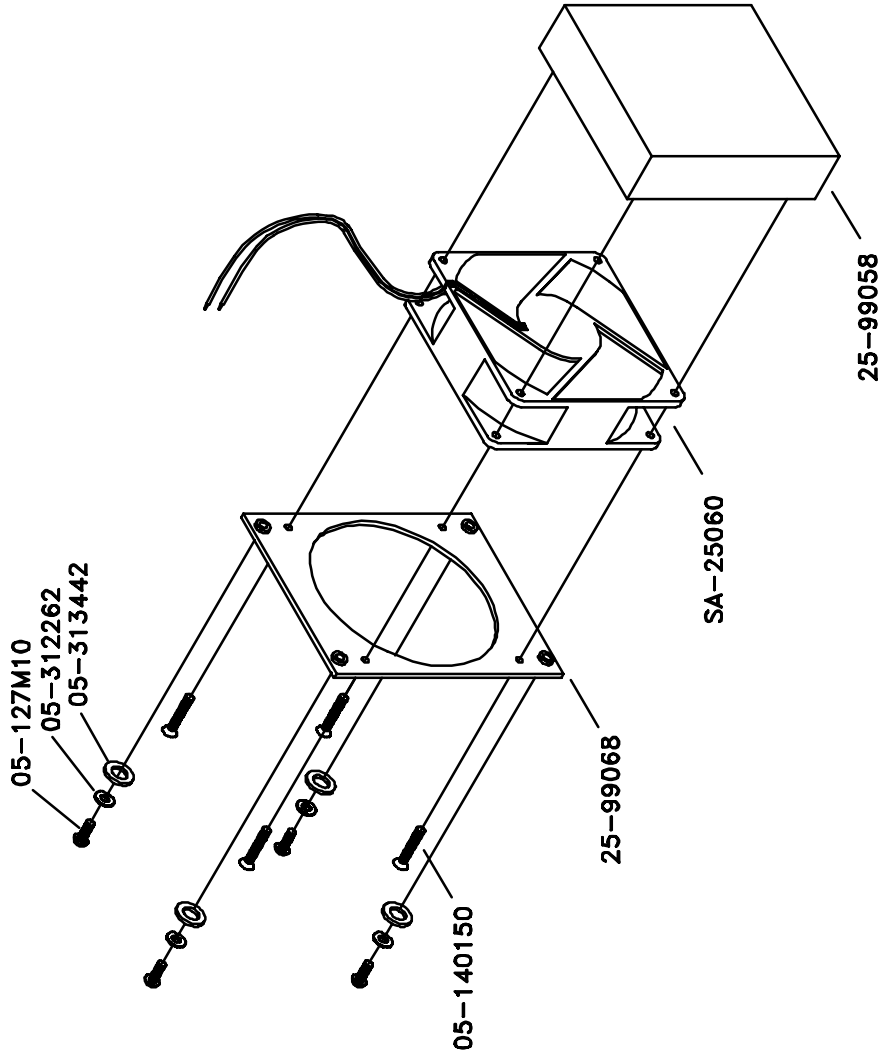

C248T13, 7/21/98

C248T14, 7-22-98

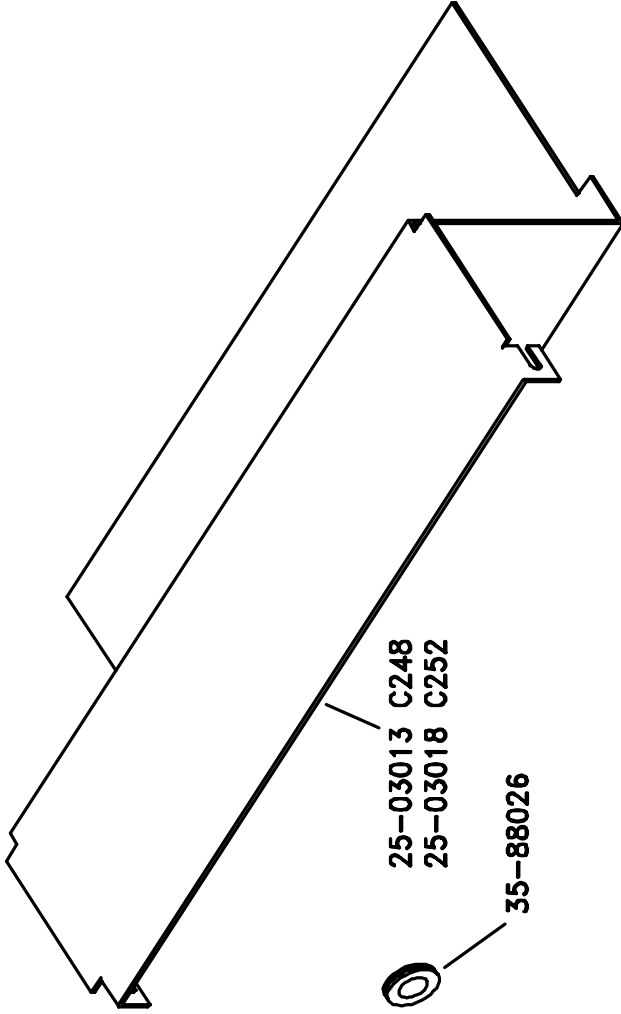

HAMADA C248/C252 NEW STYLE STREAM FEED

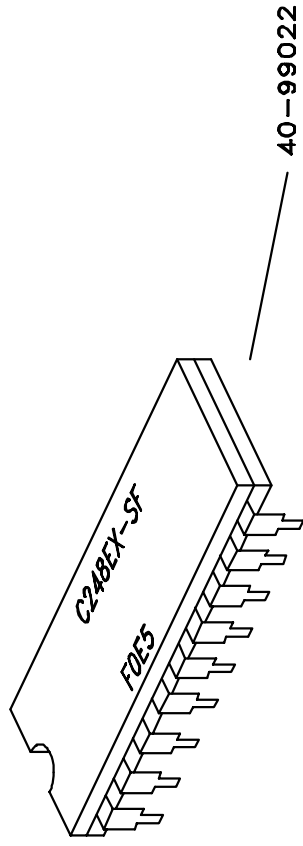

C248T15, 7-22-88

HAMADA C248/C252 NEW STYLE SHEET FEED

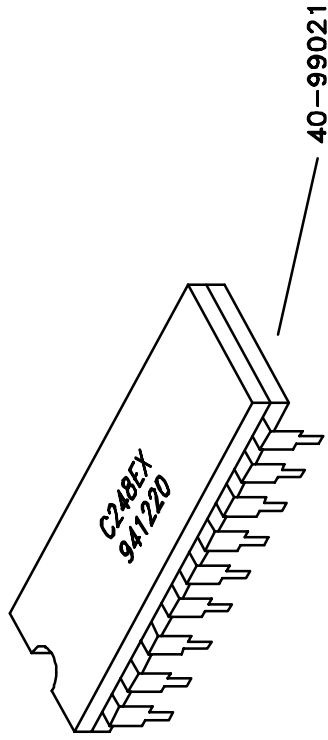

C248T16, 9-30-98

HAMADA C248 OLD STYLE SHEET FEED

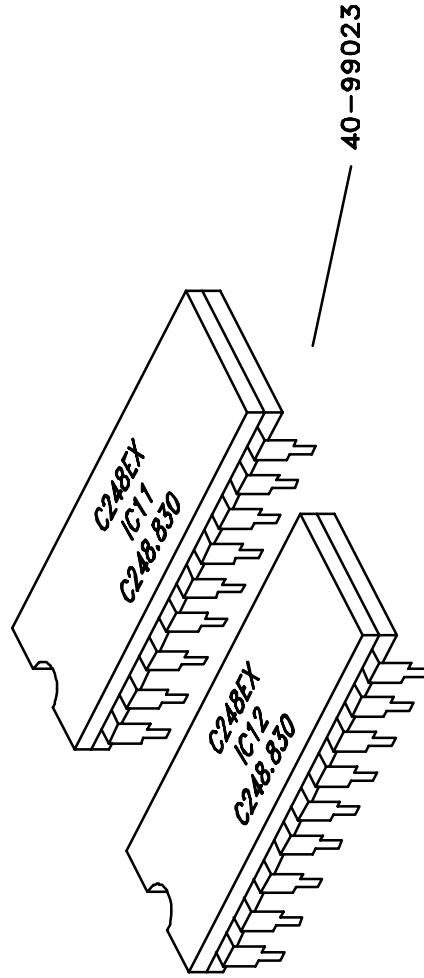

C248T17, 9-30-98

HAMADA C248 OLD STYLE STREAM FEED

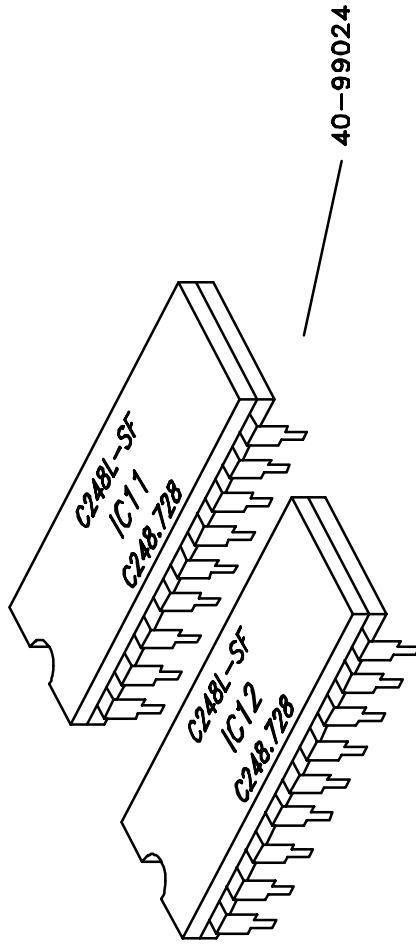

C248T18, 9-30-98

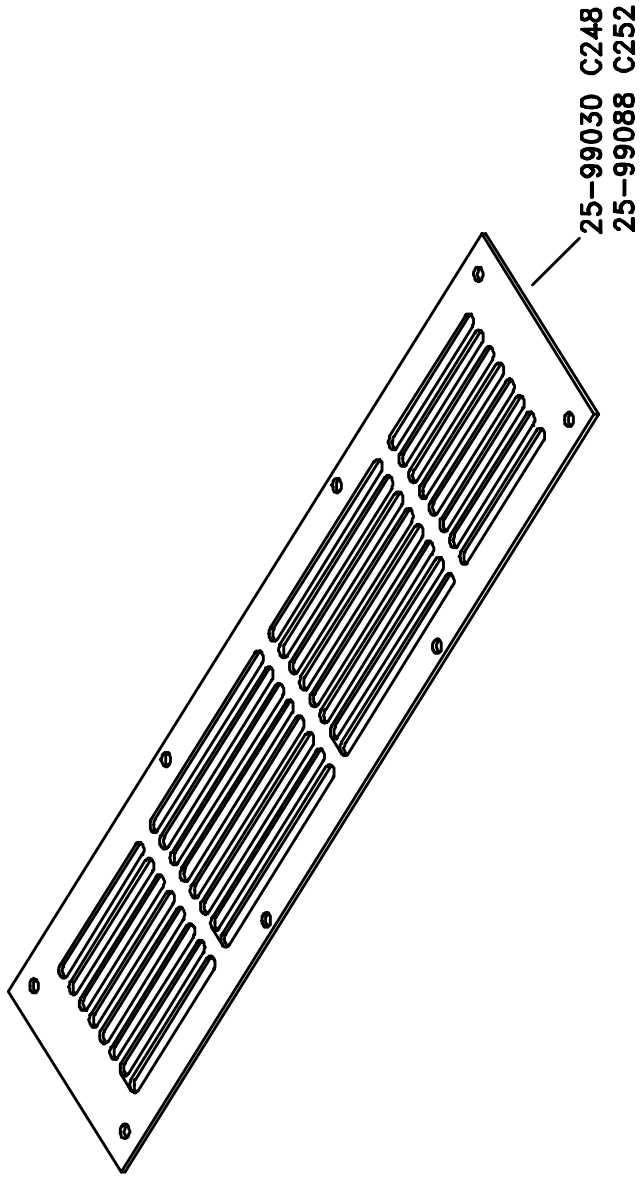

C248T19, 7-22-98

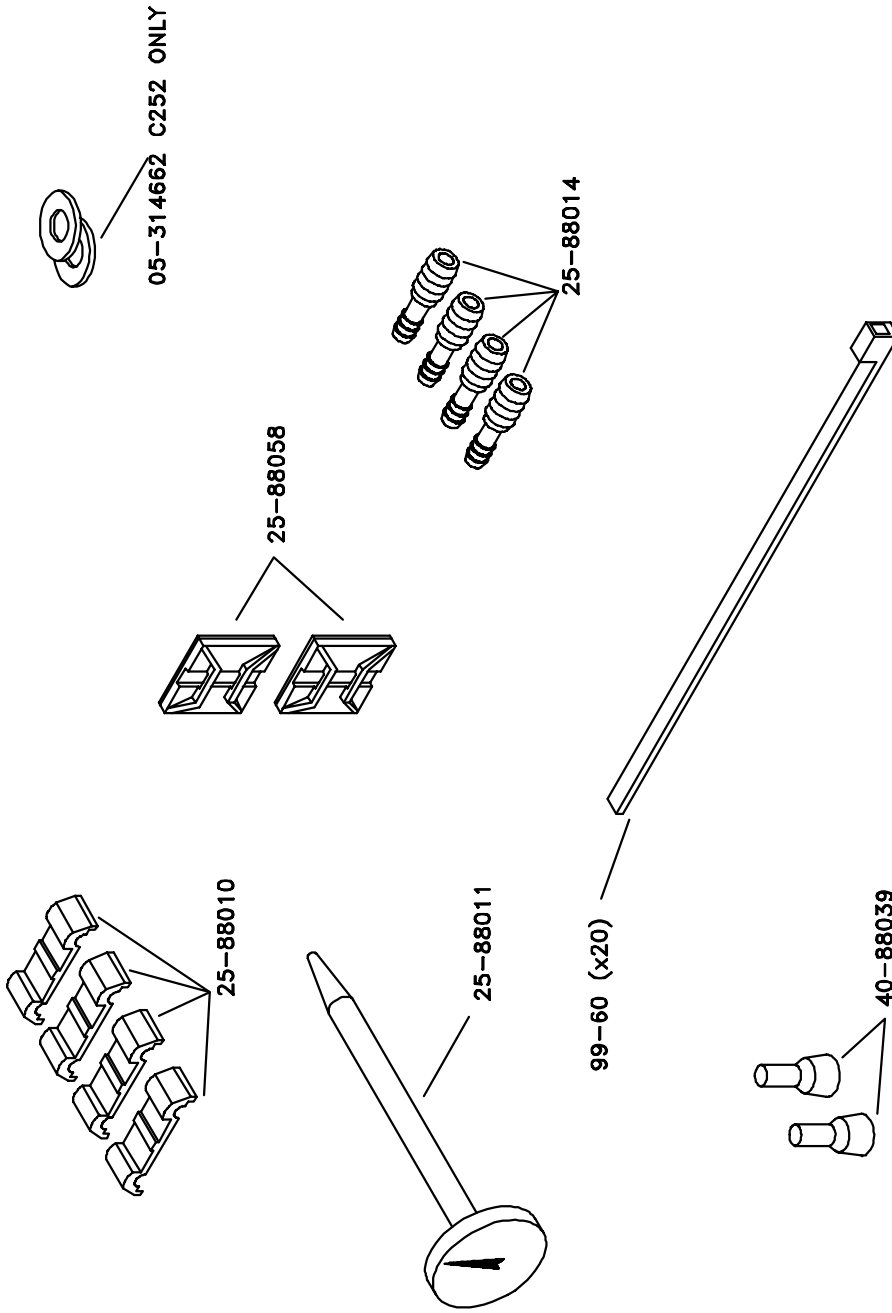

C24820, 9-28-98

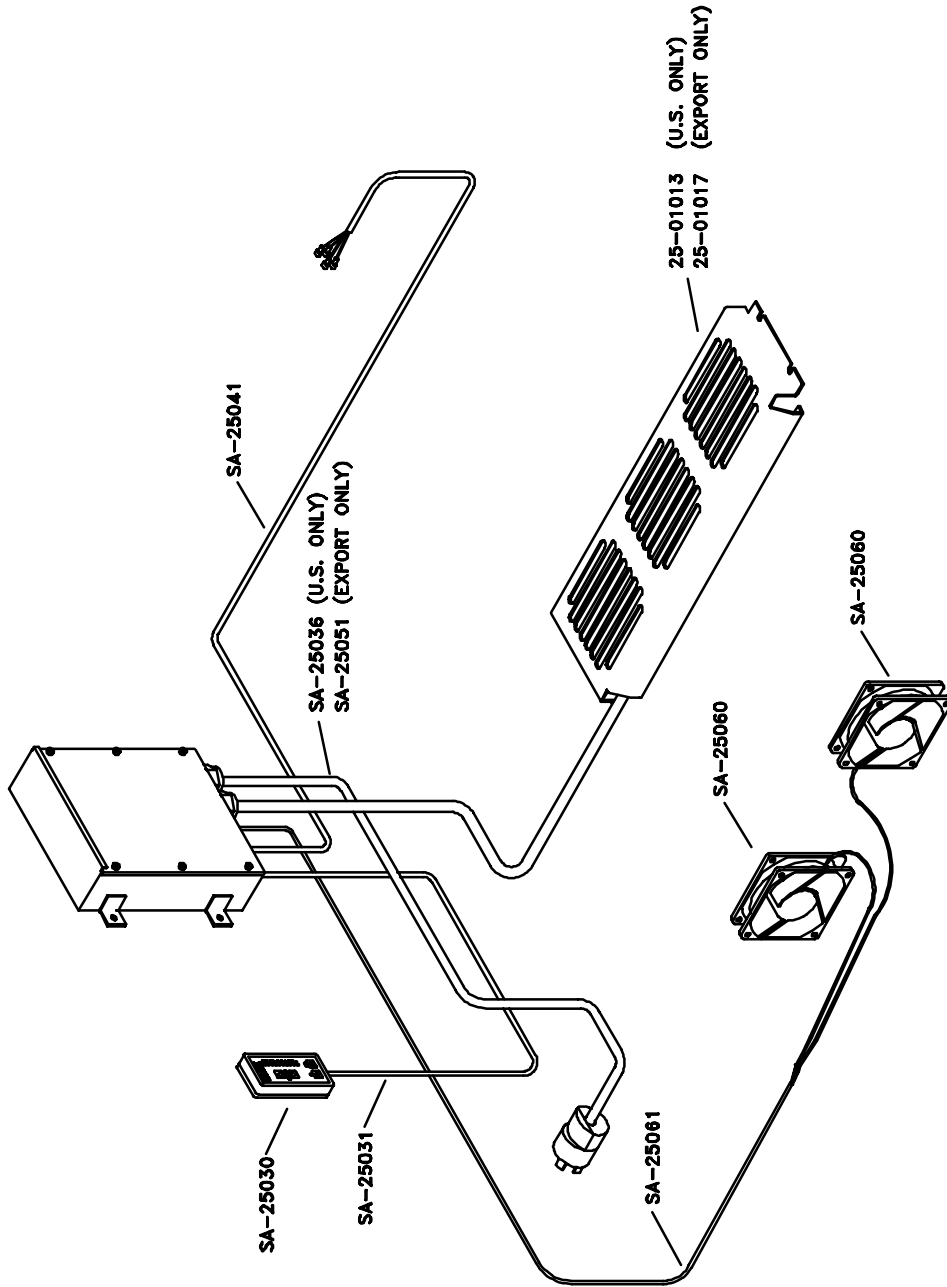

C248T21, 9-30-98

HAMADA C248/C252 TEMPEST
ELECTRICAL DIAGRAM (EUROPEAN ONLY)

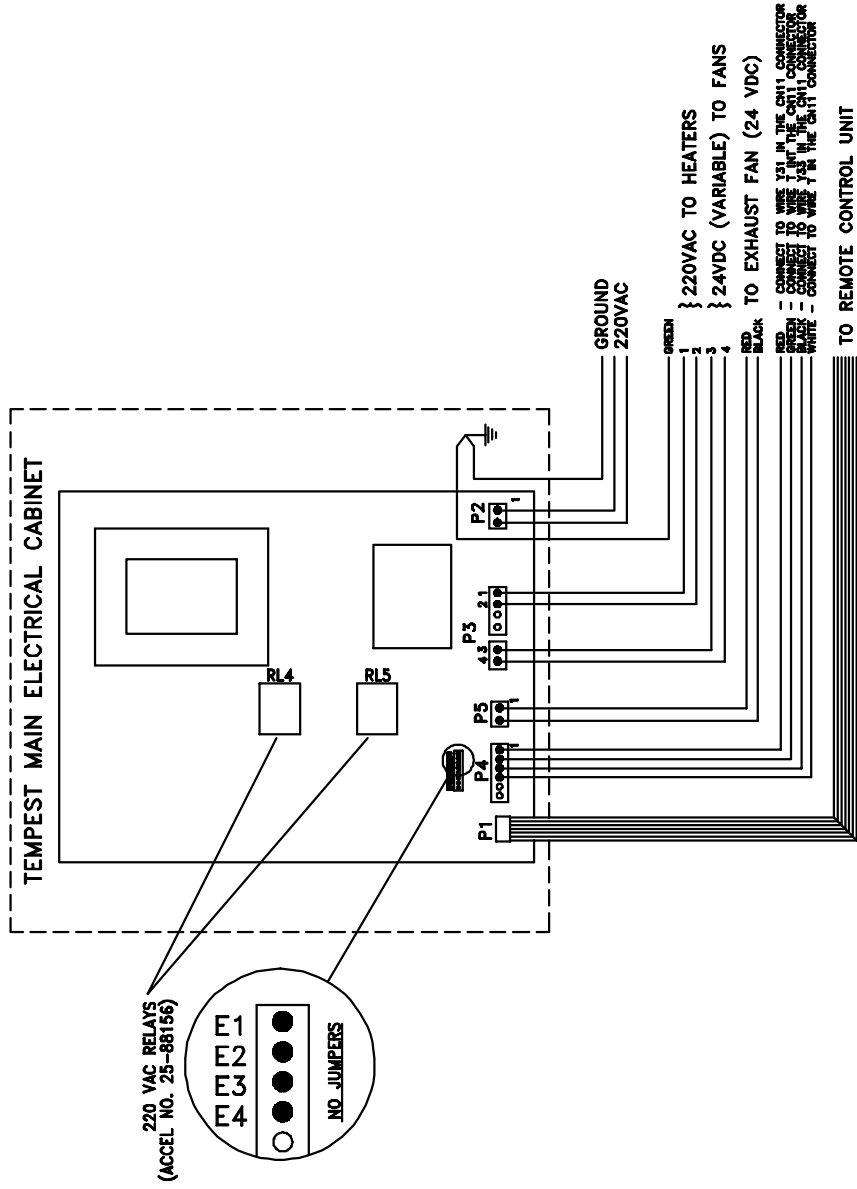

C248T22, 9-30-98

HAMADA C248/C252 TEMPEST
ELECTRICAL DIAGRAM (U.S. ONLY)

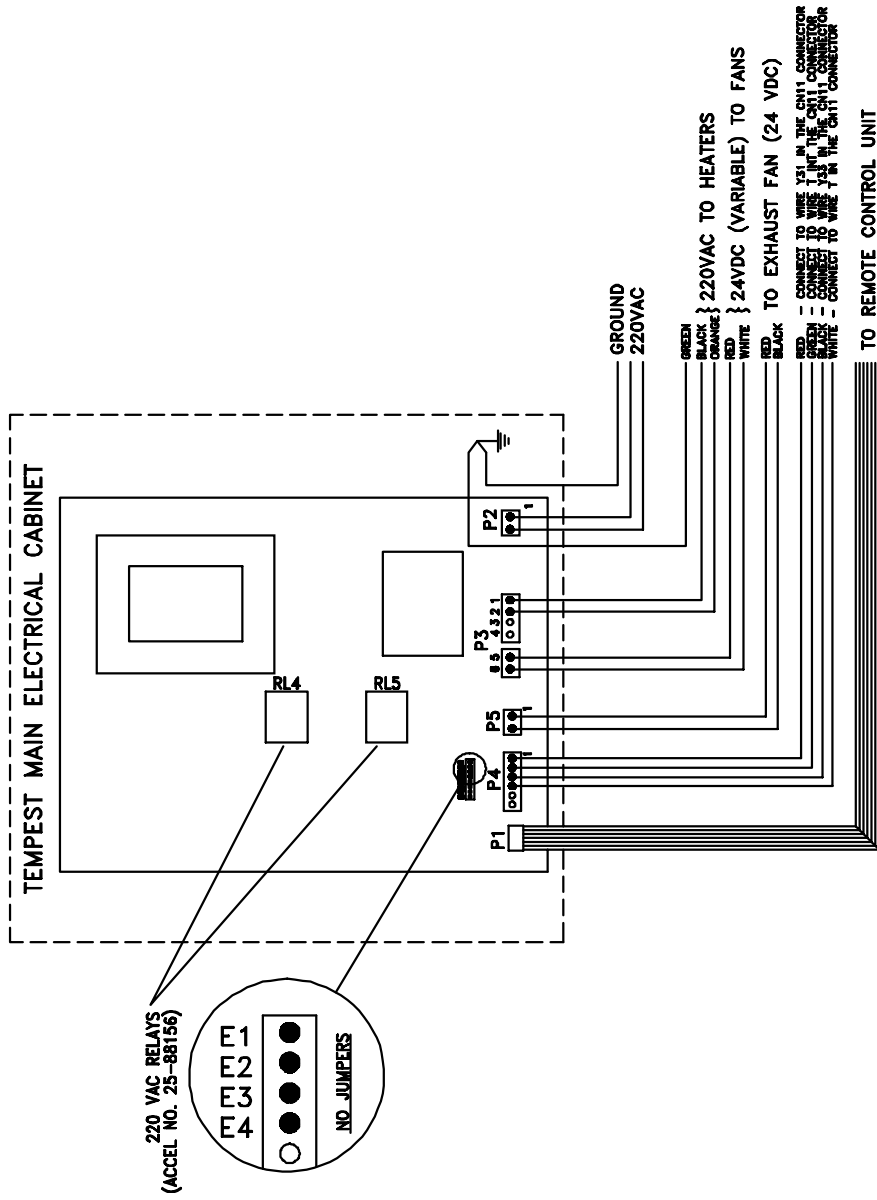

C248T23, 9-30-98

ACCEL  [®]
Graphic Systems

11103 Indian Trail, Dallas, TX 75229 Phone 972-484-6808, Fax 800-365-6510
E-mail accel@dallas.net, Web Site www.accelgraphicsystems.com