

Crestline[®] Dampening System

Installation Instructions

Ryobi 500N

ACCEL  [®]
Graphic Systems

GENERAL INFORMATION

**ATTENTION
CRESTLINE®
DAMPENER
OWNER!**

Accel Graphic Systems provides parts and service through its authorized distributors and dealers. Therefore, all requests for parts and service should be directed to your local dealer.

The philosophy of Accel Graphic Systems is to continually improve all of its products. Written notices of changes and improvements are sent to Accel Graphic System's Dealers.

If the operating characteristics or the appearance of your product differs from those described in this manual, please contact your local Accel Graphic System's Dealer for updated information and assistance.

Always update your dampener when improvements are made available, especially those related to safety.

YOUR AUTHORIZED CRESTLINE DEALER IS:

**THE SERIAL NUMBER OF YOUR
CRESTLINE DAMPENER(S) IS:**

**SAFETY
INFORMATION**

FOR YOUR SAFETY, DO NOT DISENGAGE OR REMOVE ANY GUARDS FROM THE CRESTLINE DAMPENER. THE DAMPENER CONTAINS SOME INWARD ROTATING ROLLER NIPS THAT CAN CAUSE INJURY IF LEFT UNGUARDED.

**TECHNICAL
ASSISTANCE**

For technical assistance during the installation, please contact:

**ACCEL GRAPHIC SYSTEMS
11103 Indian Trail Dallas, TX 75229
Phone (972) 484-6808
Fax (800) 365-6510
E-Mail accel@dallas.net
Web Site accelgraphicsystems.com**

GENERAL INFORMATION

BASIC CONFIGURATION OF CRESTLINE®

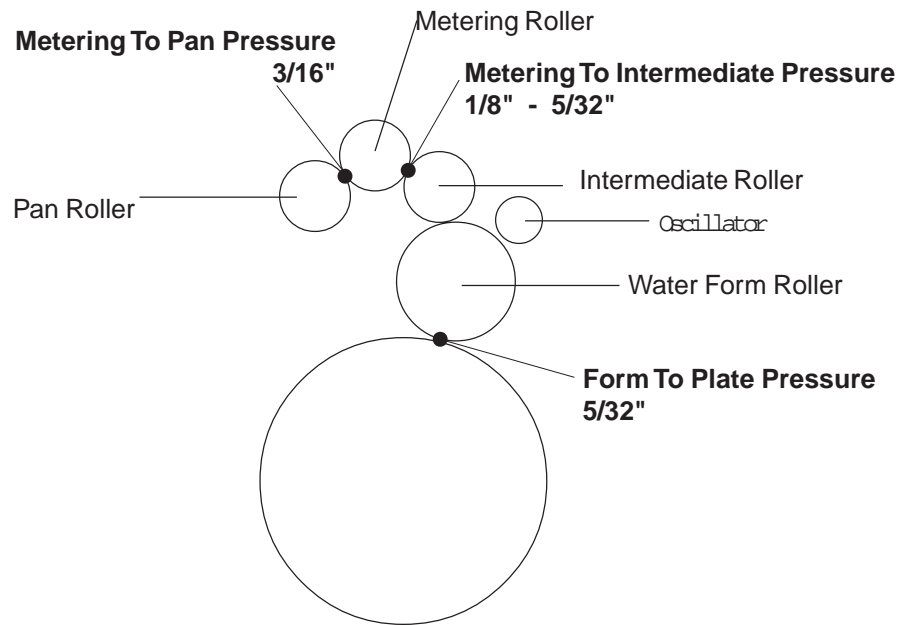

REQUIRED TOOLS

1. Phillips Screwdriver
2. Standard Screwdriver
3. 3/32" Allen Wrench
4. 1/8" Allen Wrench
5. 5/32" Allen Wrench
6. 7/16" Open End Wrench
7. 1/2" Open End Wrench
8. 2.5 mm Allen Wrench
9. 3 mm Allen Wrench
10. 4 mm Allen Wrench
11. 8 mm Open End Wrench
12. Spring Hook Tool

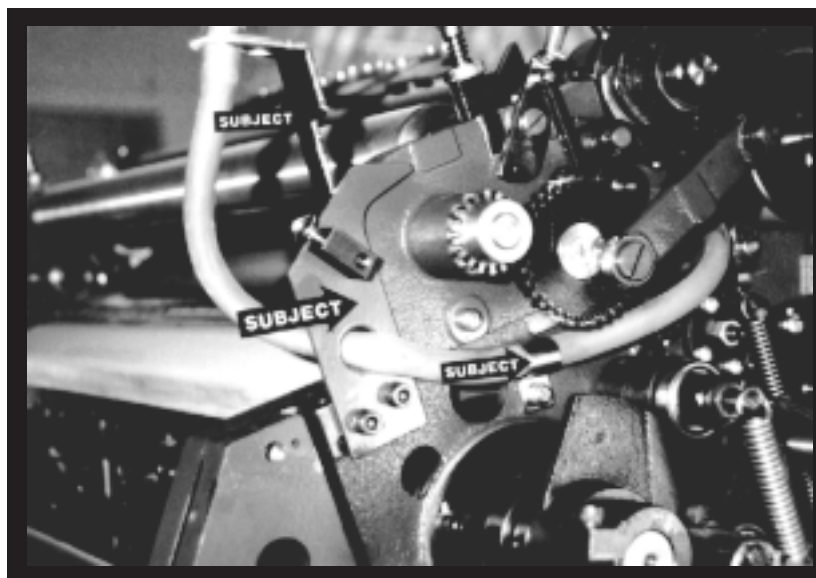
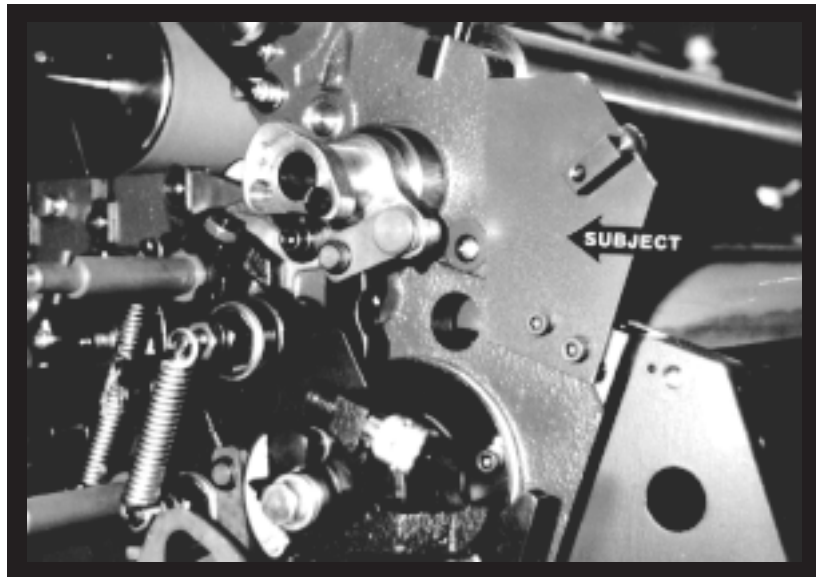

DISASSEMBLY

1

AT OPS & NOPS, remove operating handles and side covers. Also remove molleton covered rollers from existing dampener.

2

Remove plate at OPS (subject arrow). Save the following pieces for use in the Crestline installation:

- A. Small black block and bolt securing it to the plate.
- B. Phillips head cover screw.
- C. Bolts and lock washers securing plate to press frame.

ATTENTION! The newer model Ryobi 500N presses do not use the small black block to attach the side cover. Accel is now providing these blocks as well as the hardware to attach it to the plate.

3

Remove the plate at the NOPS (subject arrow) Save the same pieces listed in Step 4 for future use. Loosen clip (subject arrow) and remove water hose from holder (subject arrow).

5

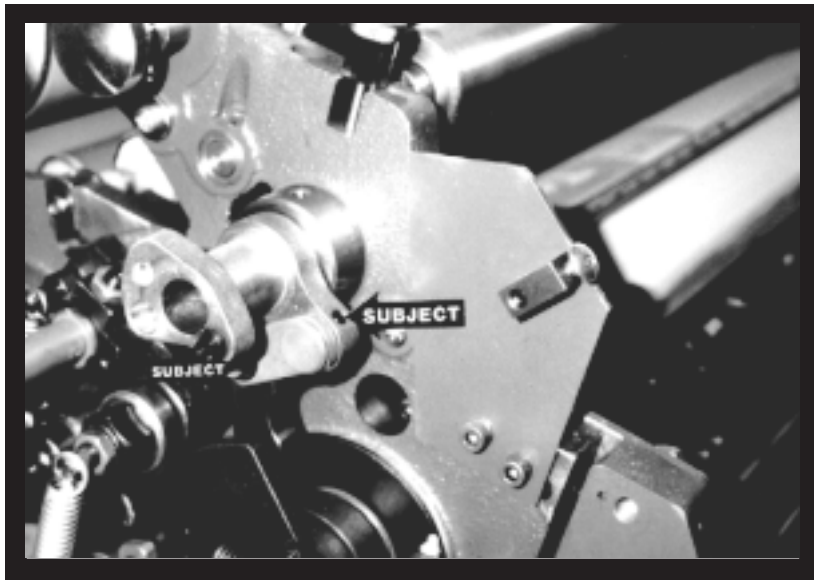

DISASSEMBLY

4

Remove "E" clip and washer (subject arrow) and save for later use. Loosen set screw (subject arrow) and remove linkage.

5

Remove the four bolts securing existing dampener to the press frames. Dampener should then be lifted off the press.

6

There are two recessed screws (subject arrow) at OPS & NOPS which secure guide pins. Replace them with the provided long set screws #05-157M25, making sure to push guide pins inward when tightening. Screws will protrude above press frame when installed.

YOU ARE NOW READY TO INSTALL CRESTLINE.

7

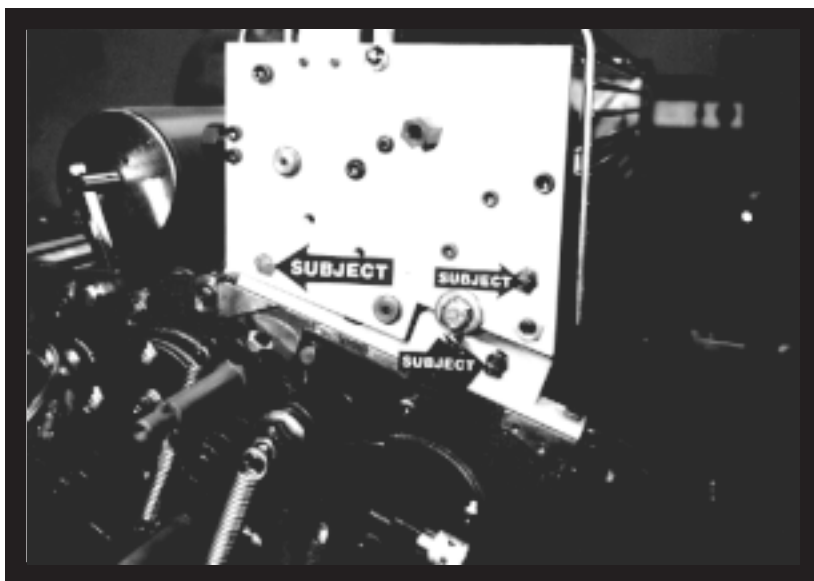
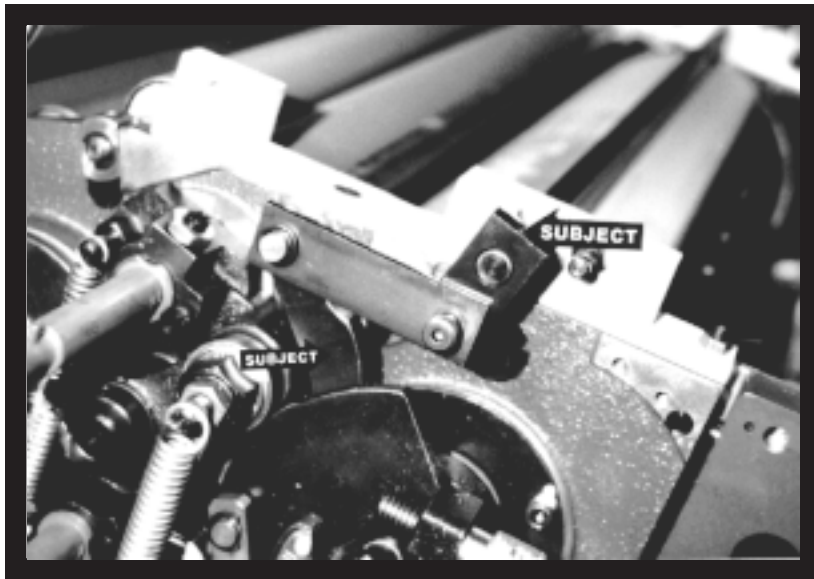
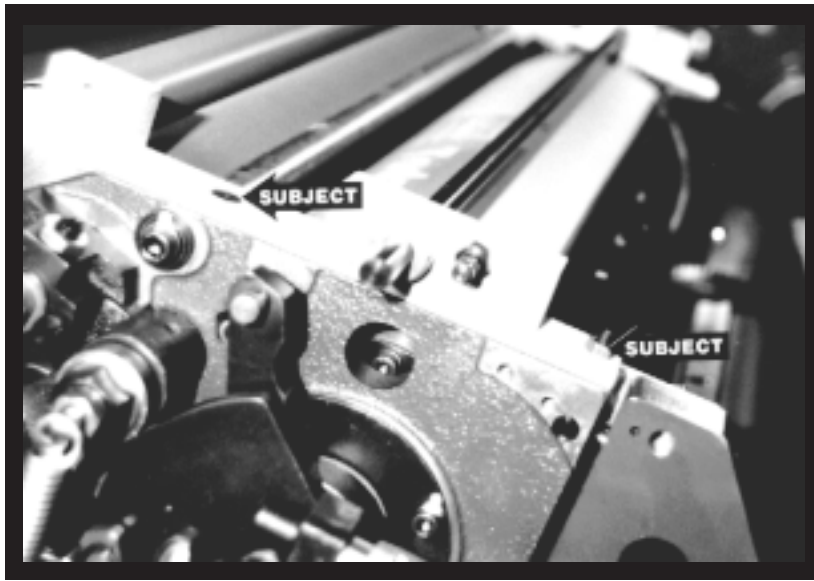

INSTALLATION

1

The dampener is shipped attached to the mounting assembly. Remove the two extension springs and pivot bolts to separate the assembly from the dampener. Place the assembly on the press frame as shown. The two protruding set screws will pass through the lower slots in the mounting brackets (subject arrow). Install provided countersunk screws #05-147M12 (subject arrow) at OPS and NOPS and tighten. Install provided nuts #05-217 on the set screws (subject arrow) and tighten. Make sure the lift shaft turns freely.

2

Install provided linkage as shown. Use washer and "E" clip from old single lever linkage to attach to press arm (subject arrow). Do not tighten set screw in control block (subject arrow) at this time.

NOTE: Behind arm (subject arrow) there may be a bearing . Push

3

the bearing inward to position the arm as shown. Place the dampener on the frame work. Install the bolts #05-114075 and pivot spools #12-999 (subject arrow) and springs #09-0101 between the studs (subject arrow). Make sure the dampener form roller is centered relative to the ink form rollers.

9

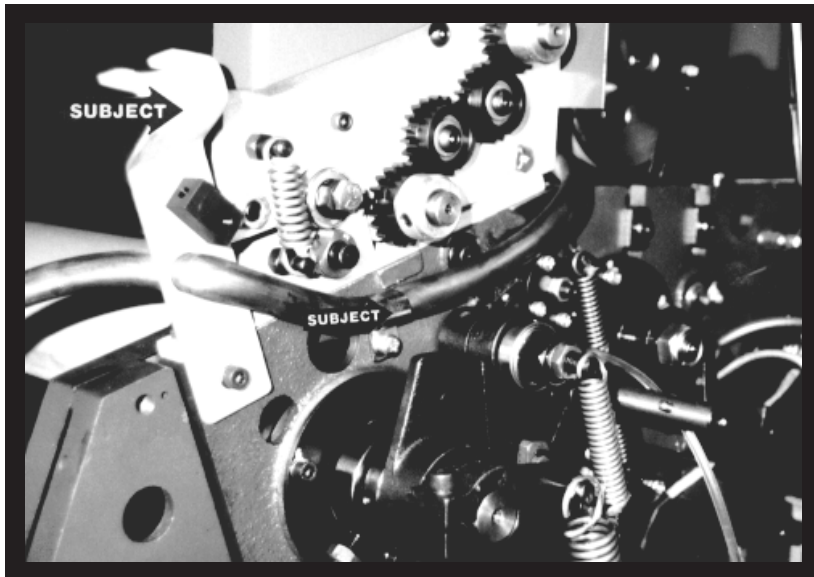
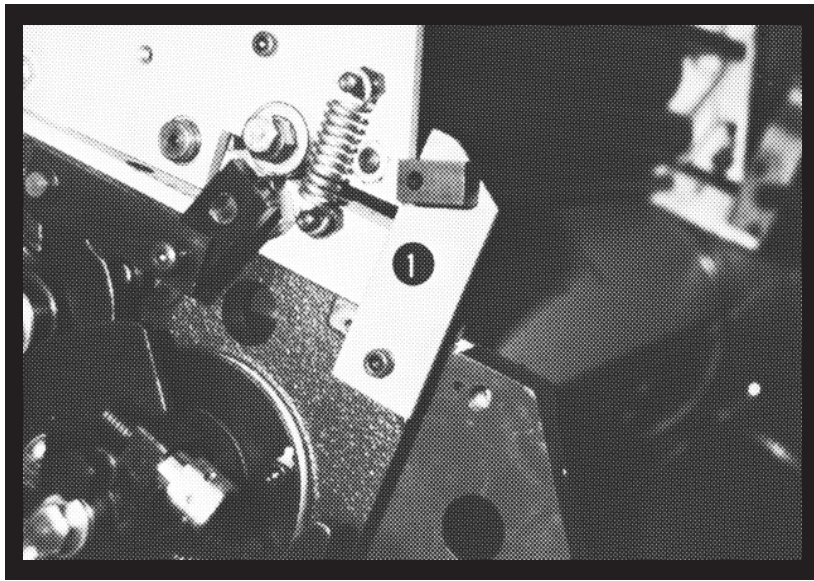

INSTALLATION

4

Install the OPS press cover mounting plate #18-0311 (subject arrow). Make sure that the cover screw block is on the outside as shown in the picture. Position and angle the plate as shown when installing.

5

Install the NOPS press cover mounting plate #18-0312 (subject arrow). Make sure that the cover screw block is on the outside as shown in the picture. Angle the plate as shown when installing. Route the water hose #99-29 from the pan through the clip (subject arrow). Tighten clip. Replace the metal cap from the end of the old water hose onto the new one.

YOUR ARE NOW READY TO MAKE FINAL ADJUSTMENTS.

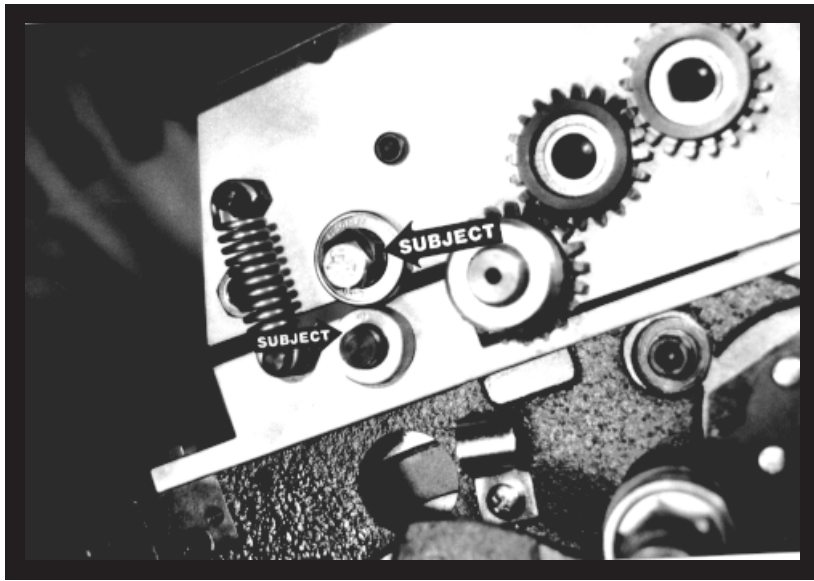

FINAL ADJUSTMENTS

1

LIFT ADJUSTMENT

Operate the single lever a few time and make sure things are moving smoothly. Place the single lever in the "dampener on" position. Position the cam (subject arrow) so that the flat side is approximately parallel with the top of the mounting block and tighten set screw in black control block. Return single lever to the "Off" position. The lift cams should then rotate and the round portion should pass underneath adjusting eccentrics (subject arrow). Adjust the eccentrics on the OPS & NOPS to get an even .030" - .040" gap between the dampener form and plate cylinder. **WARNING: Do no change the position of the cams on the shaft. They are paralleled at the factory.**

2

FORM ROLLER TO PLATE CYLINDER PRESSURE

Mount a plate on the press. Dab some ink on the dampener oscillator and turn on the press to distribute. Turn off the press and lower the dampener to the plate to check the stripe. The proper setting is an even $5/32$ " (4mm) across the plate. Adjust the stripe by turning the screws (subject arrow) in the blocks. Turning the screws down makes a thinner stripe and vice versa. Adjust to $5/32$ " (4mm) and secure the screws with the lock nuts.

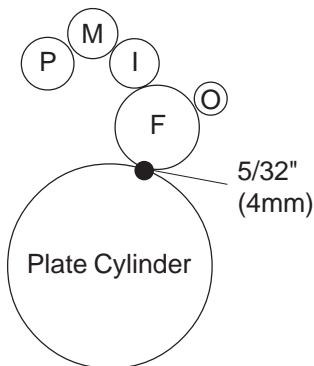

3

INTERMEDIATE TO METERING ROLLER PRESSURE

Next check the stripe between the intermediate and metering rollers by dropping the dampener to the plate and turning the press backwards by hand. The strip should be parallel and between $1/8$ " and $5/32$ " (3-4mm). If not, loosen top screw in hanger brackets. Also loosen bottom screws, but keep a little tension against the hanger brackets. The hangers will pivot around bottom screw since the top screw hole is oversize. Reset brackets as needed and retighten all screws.

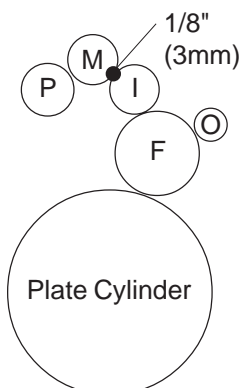

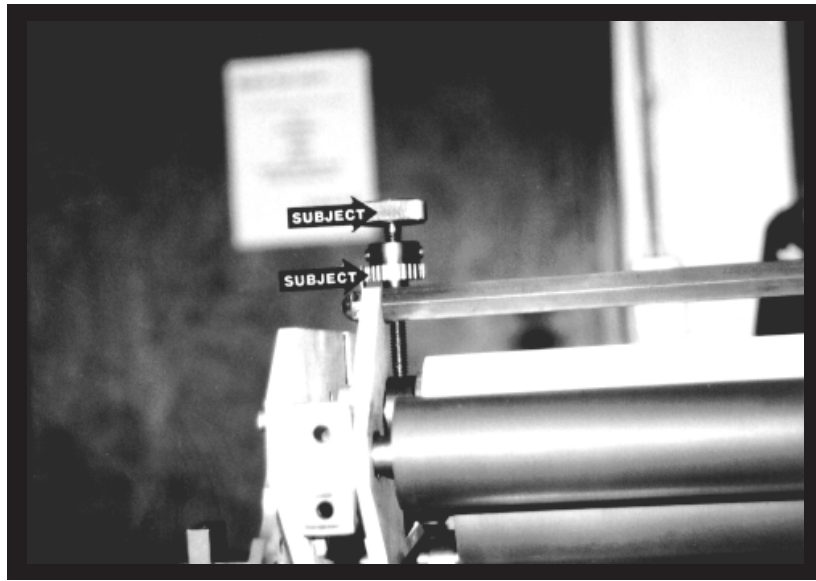

FINAL ADJUSTMENTS

3/16"
(5mm)

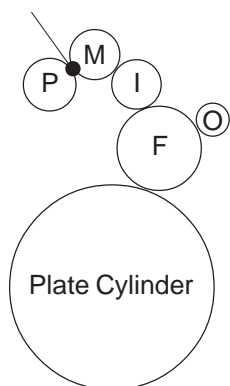

4

MAXIMUM METERING TO PAN ROLLER PRESSURE

Place the dampener in the "Off" position. Turn the press on and let the press idle for 20 seconds. After the press sits still for 20 seconds, check the stripe between the pan and metering rollers by bumping hand wheel. It should be 3/16" (5mm). Adjust by turning the knurled knobs (subject arrow). Turning the knobs down makes a wider stripe. The ratchet gear (subject arrow) is not locked to the knob at this time.

Once the pan to metering roller has been set at 3/16", spin ratchet gears down (while holding the knobs still) until they bottom out on the stud and lock in place with set screws. This position is minimum water.

5

Apply a small amount of grease on the dampener gears, lift cams, and springs.

6

Reinstall the upper press side covers and adjust the cover screw blocks on the plates (plates installed in Steps 4 & 5, Dampener Installation Instructions) to hold the covers properly. Tighten phillips head cover screws.

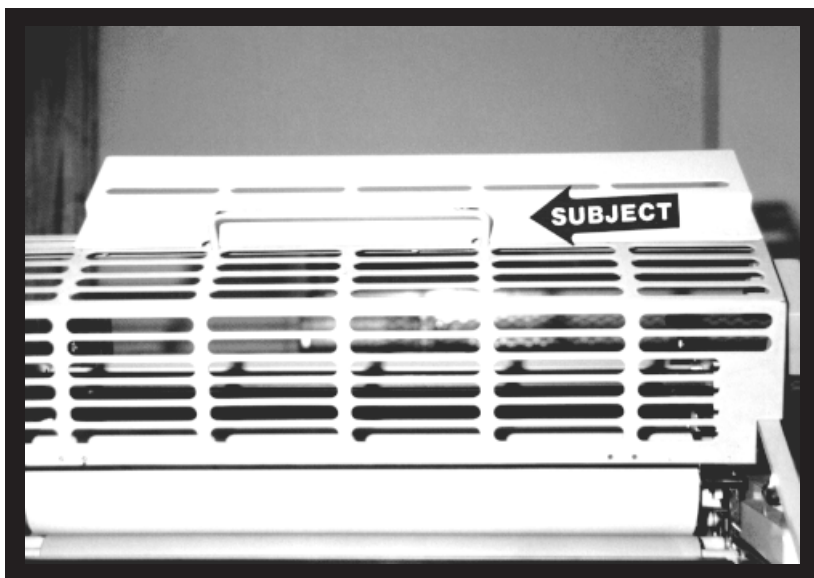

FINAL ADJUSTMENTS

7

LEVEL OF WATER PAN

Place full water bottle in dampener pan and check water level. It should be about half way up the pan. Adjust bottle if necessary. Raising bottle bracket will raise the water level and vice-versa.

8

Remove old plate cylinder guard. Install new, shorter cylinder guard #18-0205 using the same hinges as before.

9

Attach inker extension guard #18-0325 as shown using 3 flanged nuts #05-244 provided. (View is from ink fountain looking back toward feeder.)

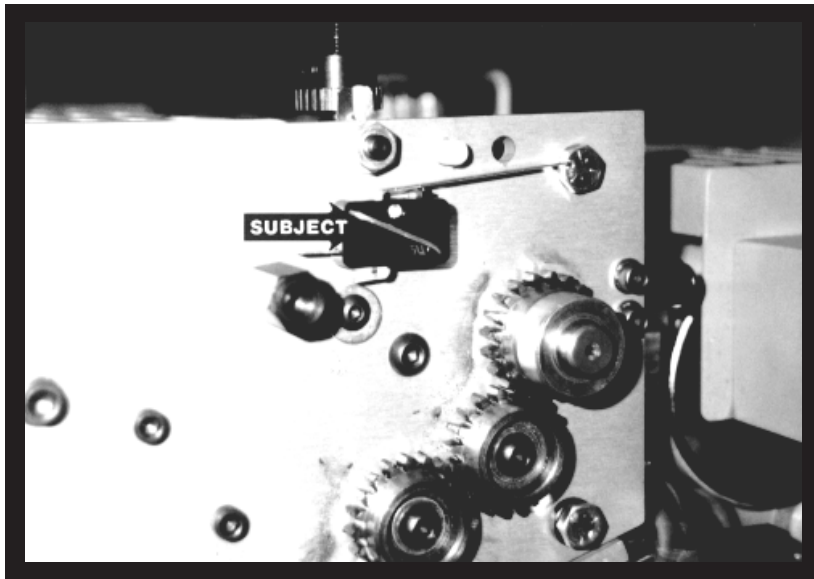
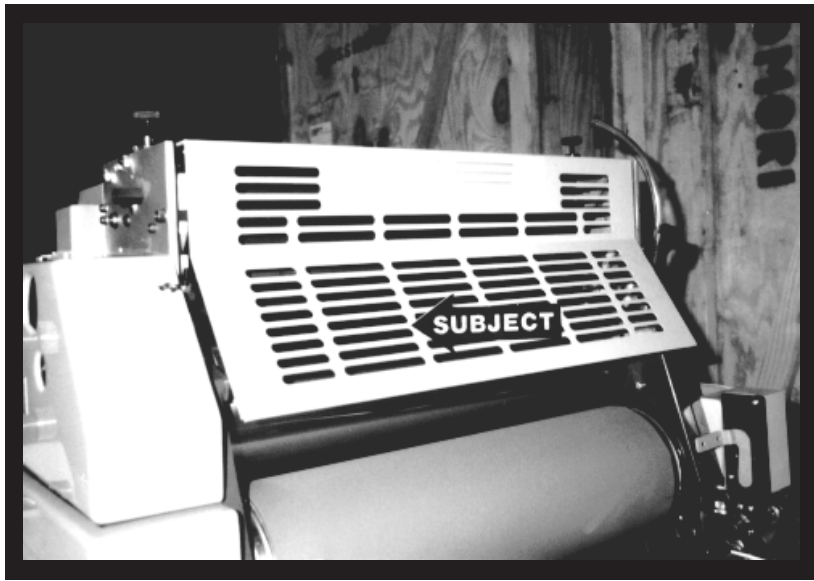

FINAL ADJUSTMENTS

10

Attach dampener guard #18-0120 by sliding pivot rod through the 1/4" holes nearest the thumb screws and center guard on dampener.

11

Place trip cam #14-06 at the NOPS (subject arrow). A set collar #13-2531 is provided to secure the OPS.

12

Remove press microswitch cover at NOPS. Disconnect the common wire from the press microswitch and run the new wires as diagrammed. Secure new wires with provided zip ties making sure they are clear of all gears and moving parts. Replace press switch cover when finished. Install dampener side covers. The one with the cutout goes to the NOPS.

THE DAMPENER IS NOW READY TO RUN.

NOTE: For a better view of the wiring diagram, see parts section drawing #SK11591A in the back of this manual.

19

BASIC OPERATION

- START OF DAY**
- A.** Make sure all rollers are secure in their proper position.
 - B.** Turn knurled knob on ratchet assembly clockwise until it stops.
 - C.** Before adding water, ink-up the dampener. This is done either by applying a small amount of ink directly to the dampener oscillator, or by dropping both water and ink from rollers to the plate and allowing the dampener to ink-up from the plate.
 - D.** Place water bottle in bracket. Accel recommend using the proper fountain solution formulated for the specific plate type being run on the press.

-
- RUNNING DURING THE DAY**
- A.** Typically, the Crestline Dampener should not have to be adjusted from job to job. The form roller setting should never be changed unless it has deviated from the factory specification of 5/32" to the plate.
 - B.** If necessary, the amount of water fed to the plate can be adjusted by turning the knurled ratchet knob. You are running minimum water with the knob turned fully clockwise. If you need more water, loosen the lock-knob, turn ratchet assembly counterclockwise one "click" at a time until proper moisture is achieved, then retighten lock knob. Make sure the arm on the pan roller shaft follows the black eccentric on the ratchet assembly. If necessary, turn the knurled knob on the pan roller shaft until the aluminum arm stops against the eccentric.

CLEANING & MAINTENANCE

WASH UPS DURING THE DAY

1. Remove bottle and drain the excess water from the pan.
2. Mount a cleanup mat to the press.
3. Turn on the press and squirt a small amount of press wash on the ink rollers and dampener oscillator. Avoid excessive application of wash to the dampener or most of it will end up in the water pan. Do not use an extremely fast drying wash on the dampener as this can damage soft rubber. Fast-dry washes should only be used on blankets!
4. Drop both the dampener and ink forms to the cleanup mat.
5. Remove water pan and clean any solution left in it.
6. Be sure to wipe excess clean up solution from the ends of the dampener metering and pan rollers.

END OF THE DAY

1. Wash up dampener as describe above. Pay close attention to cleaning the ends of the pan and metering rollers that extend past the form rollers.
2. Spin the knurled knob counterclockwise and relieve pressure between the metering and pan rollers.
3. Remove any excess wash that may remain on dampener metering and pan rollers.

CLEANING & MAINTENANCE

DEGLAZING THE DAMPENER

Periodic deglazing of water-soluble contaminants will be necessary with the Crestline®. Typically, once every 2-3 weeks will be sufficient, unless you are running electrostatic plates on a daily basis whereas deglazing should be performed weekly. A 50/50 solution of household ammonia and hot water can be used for deglazing purposes. If you prefer a commercially available deglazer, avoid those containing pumice or gritty substances. Always follow deglazing with straight water and then roller wash

OILING AND GREASING THE DAMPENER

- A. Place a small amount of grease on the gears once a month.
- B. Inject grease into the oscillator grease fitting one a month.

CLEANING & MAINTENANCE

CRESTLINE® CLEANING & MAINTENANCE CHART

	Daily	Weekly	Bi-Weekly	Monthly
Wash Rollers	✓			
Deglaze Rollers				
Metal Plate Users			✓	
Silvermaster Plate Users			✓	
Electrostatic Plate Users		✓		
Grease Gears				✓
Inspect Ball Bearings				✓
Check Roller Pressures				✓
Check Roller Surfaces				✓

RY50N

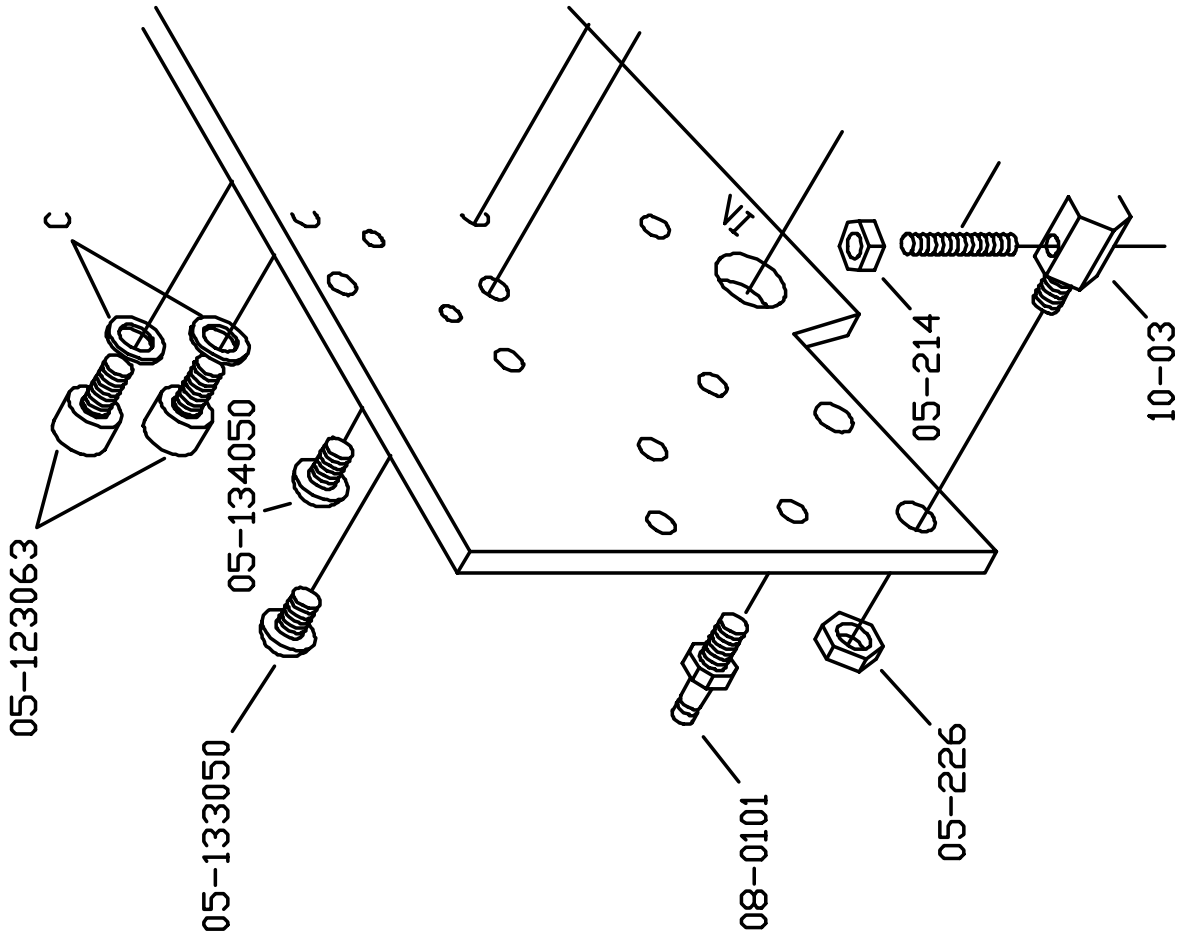

RY50N

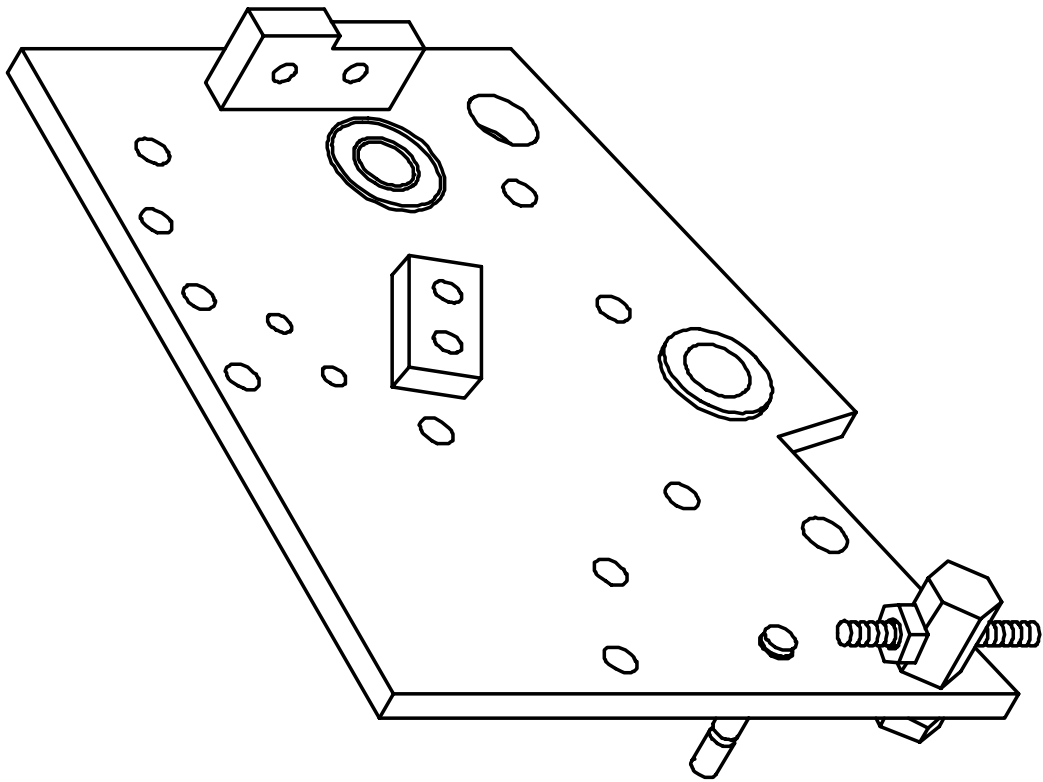

RY50N

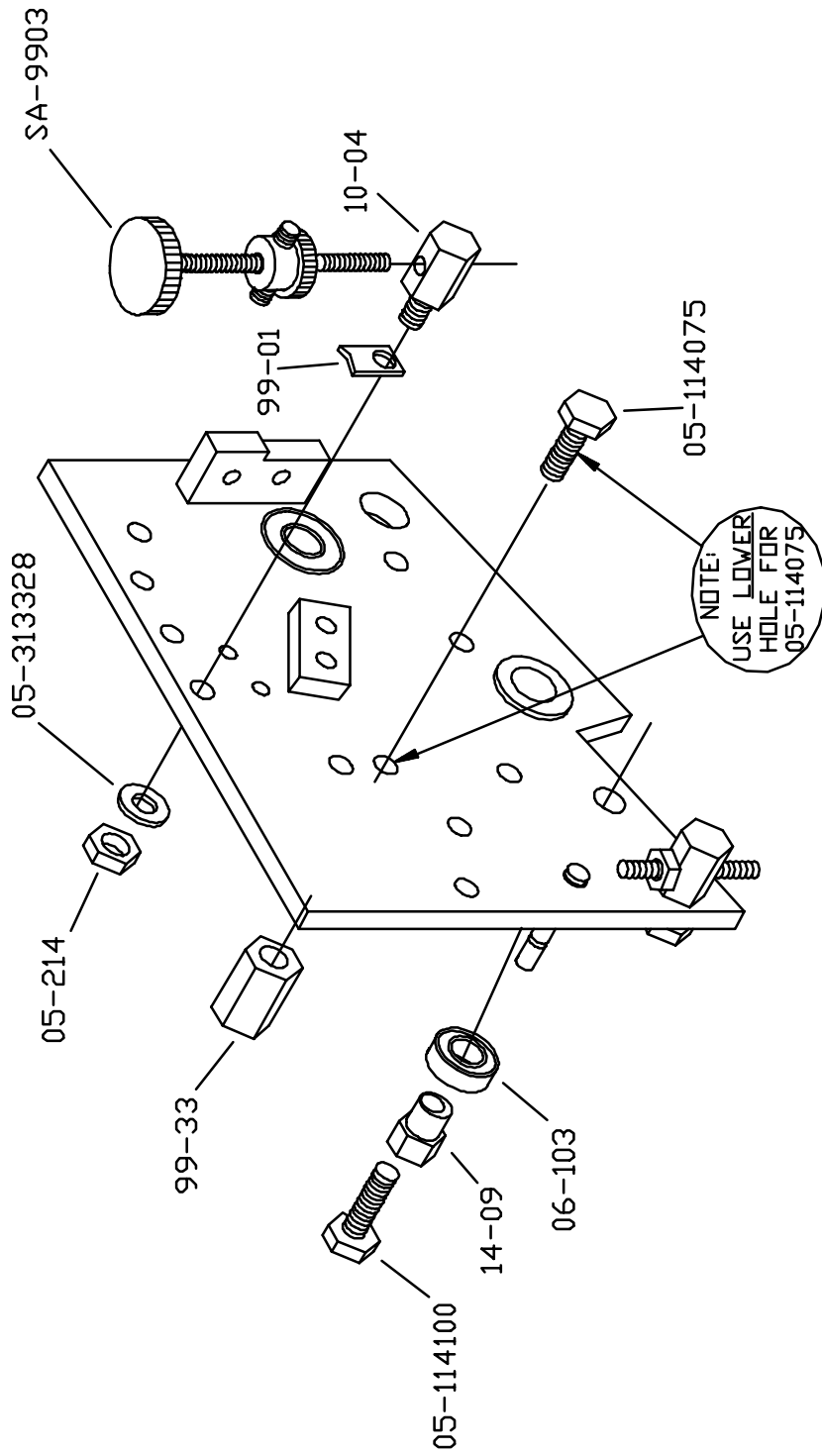

RY50N

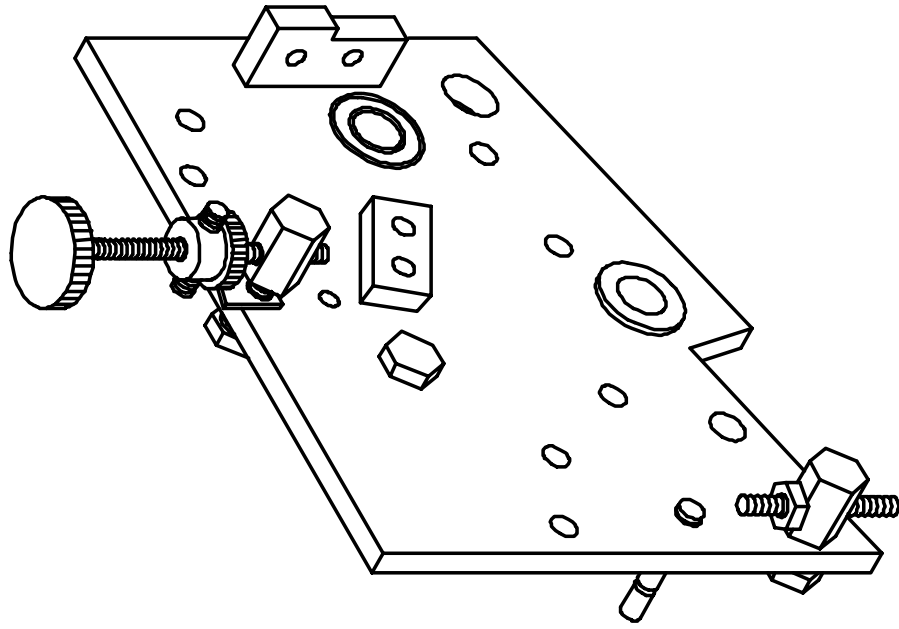

RY54, 8-96

RY50N

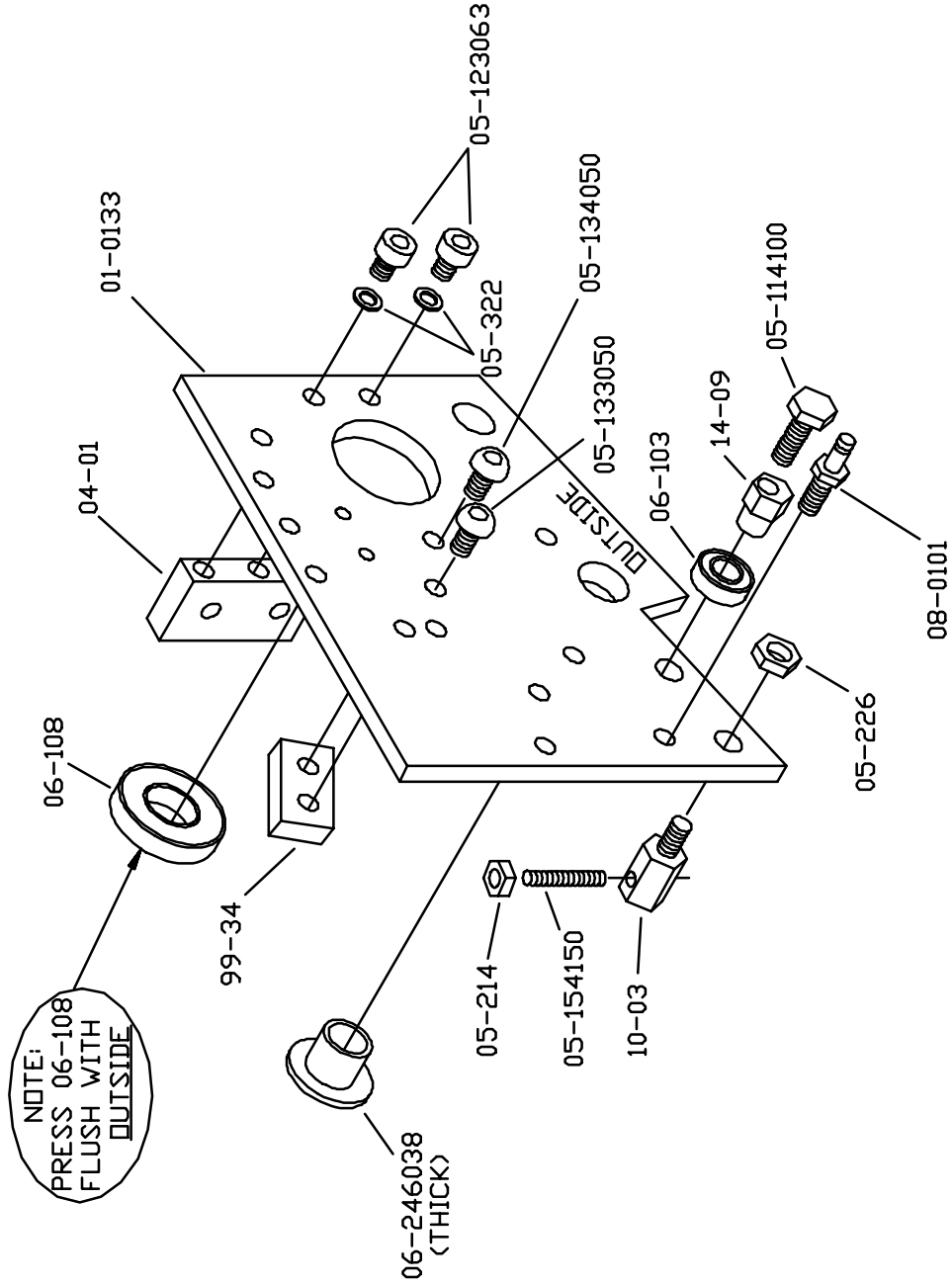

RY50N

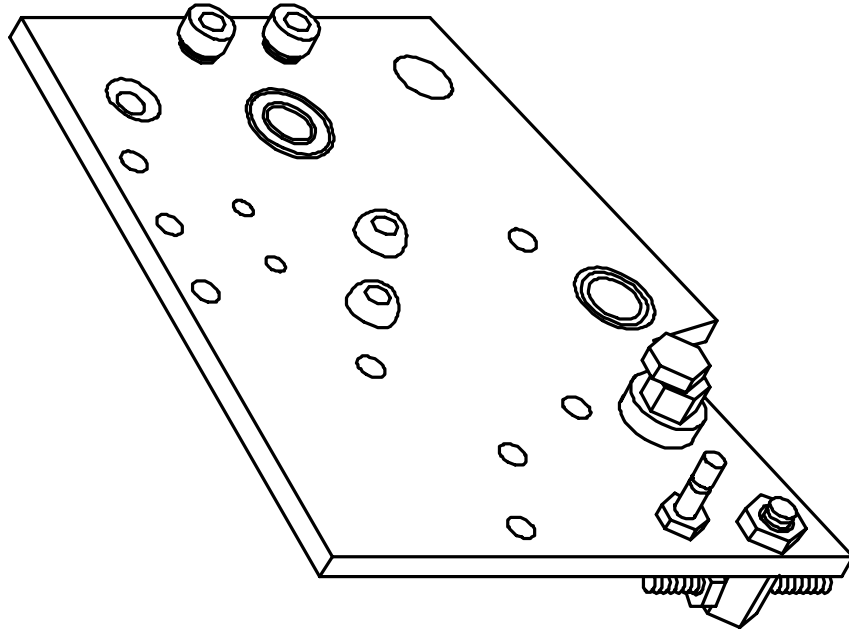

RY59, 8-96

RY50N

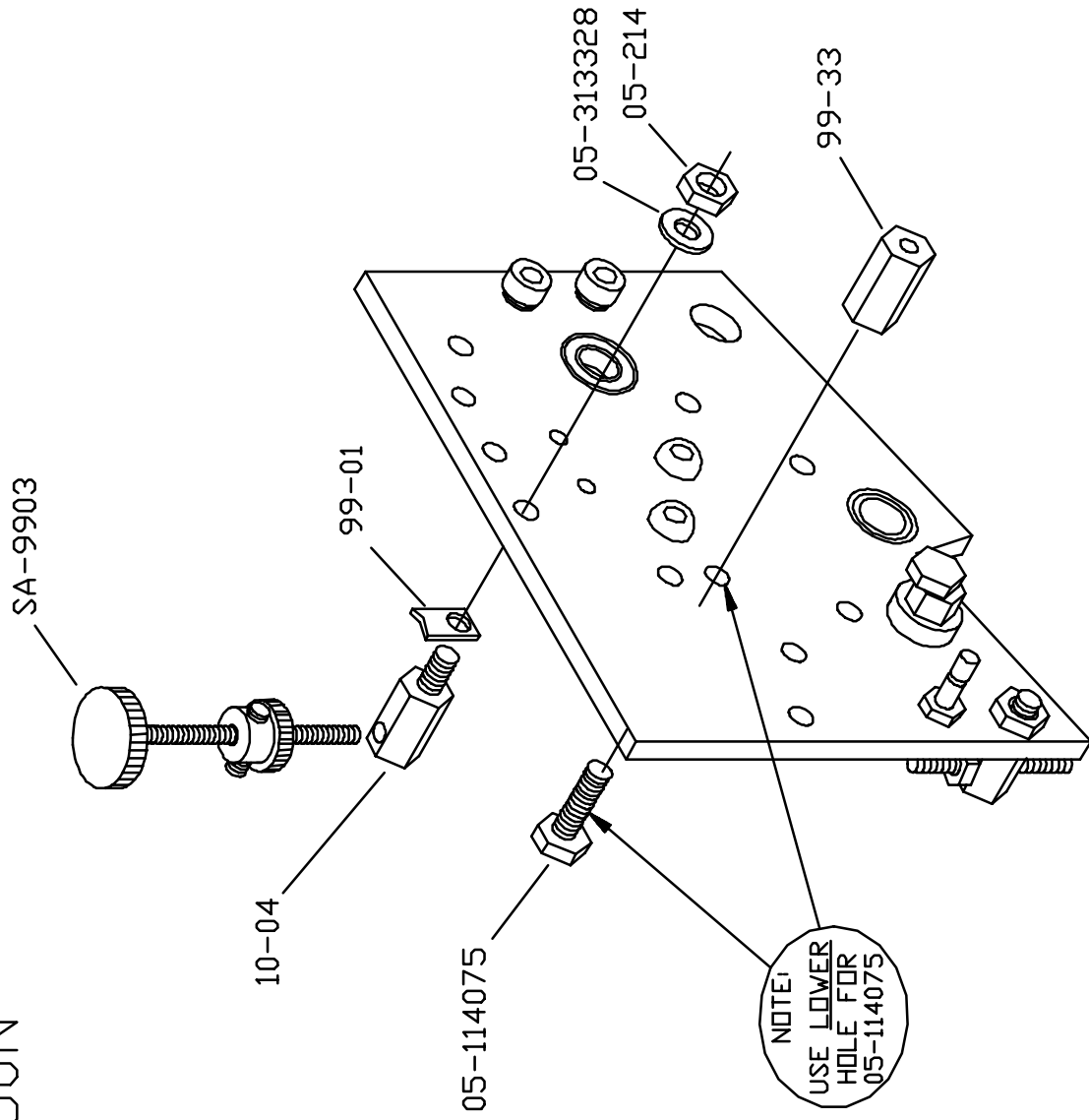

RY50N

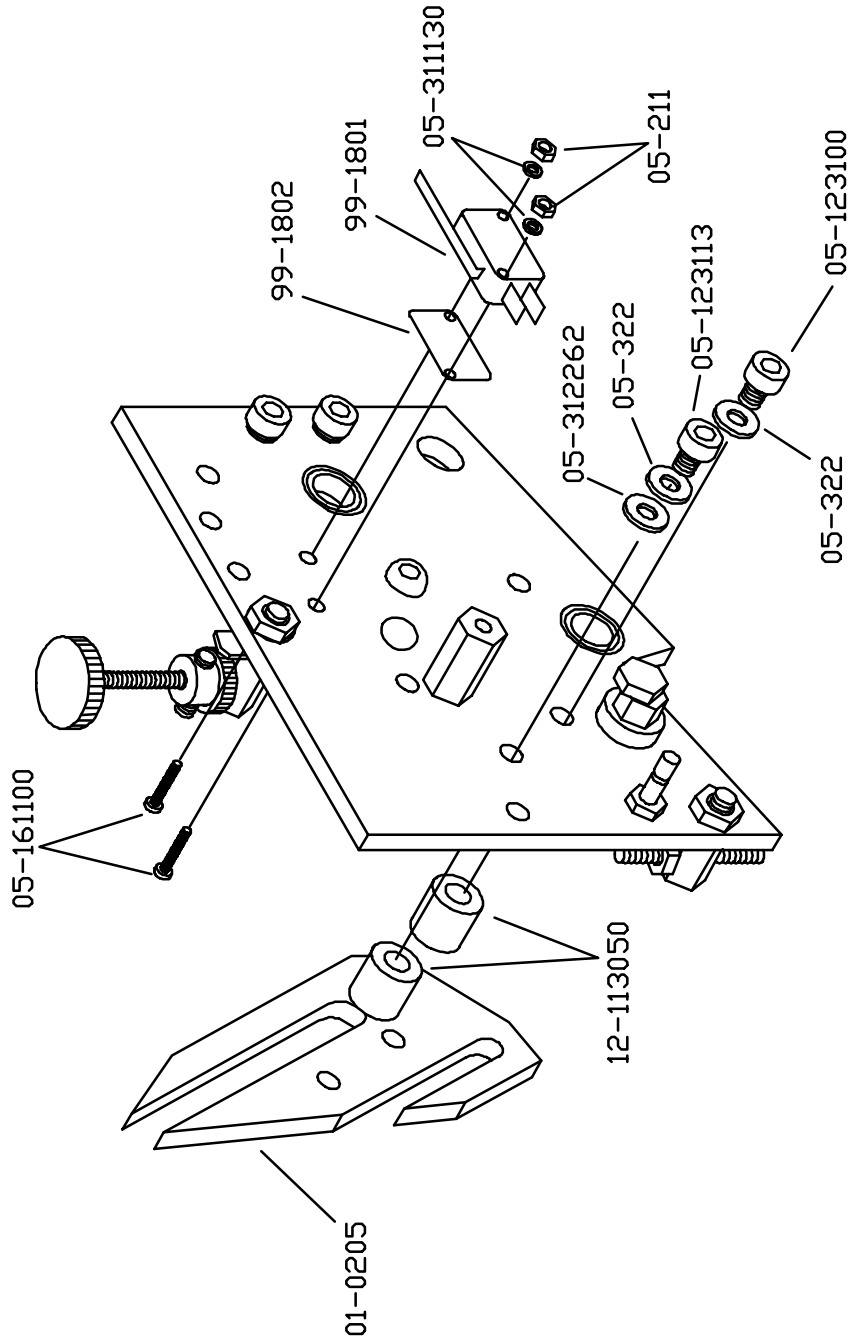

RY63, B-96

RY50N

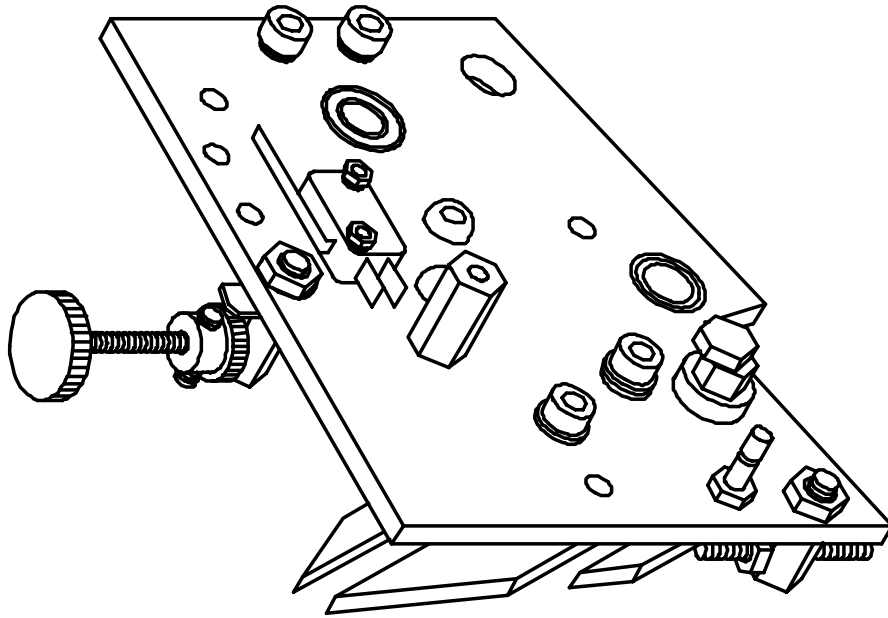

RY50N

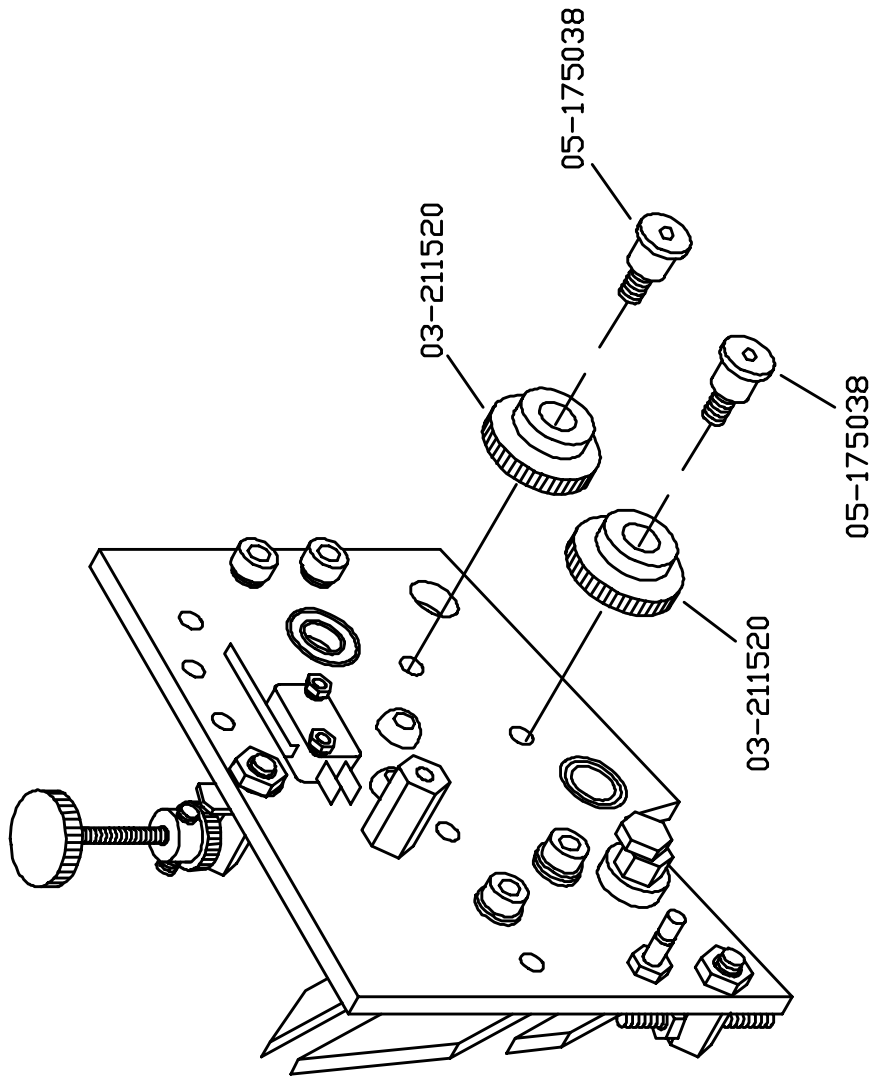

RY64, 8-96

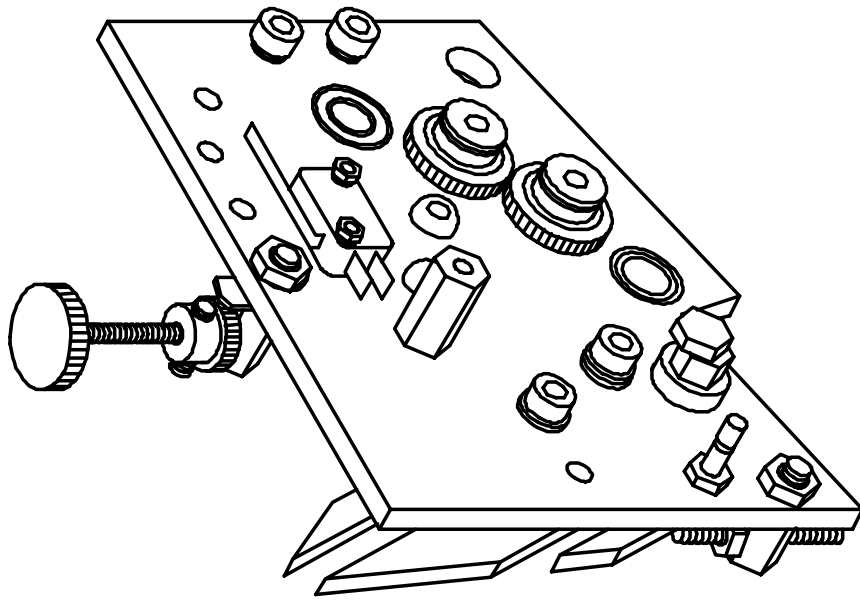

RY50N

RY50N

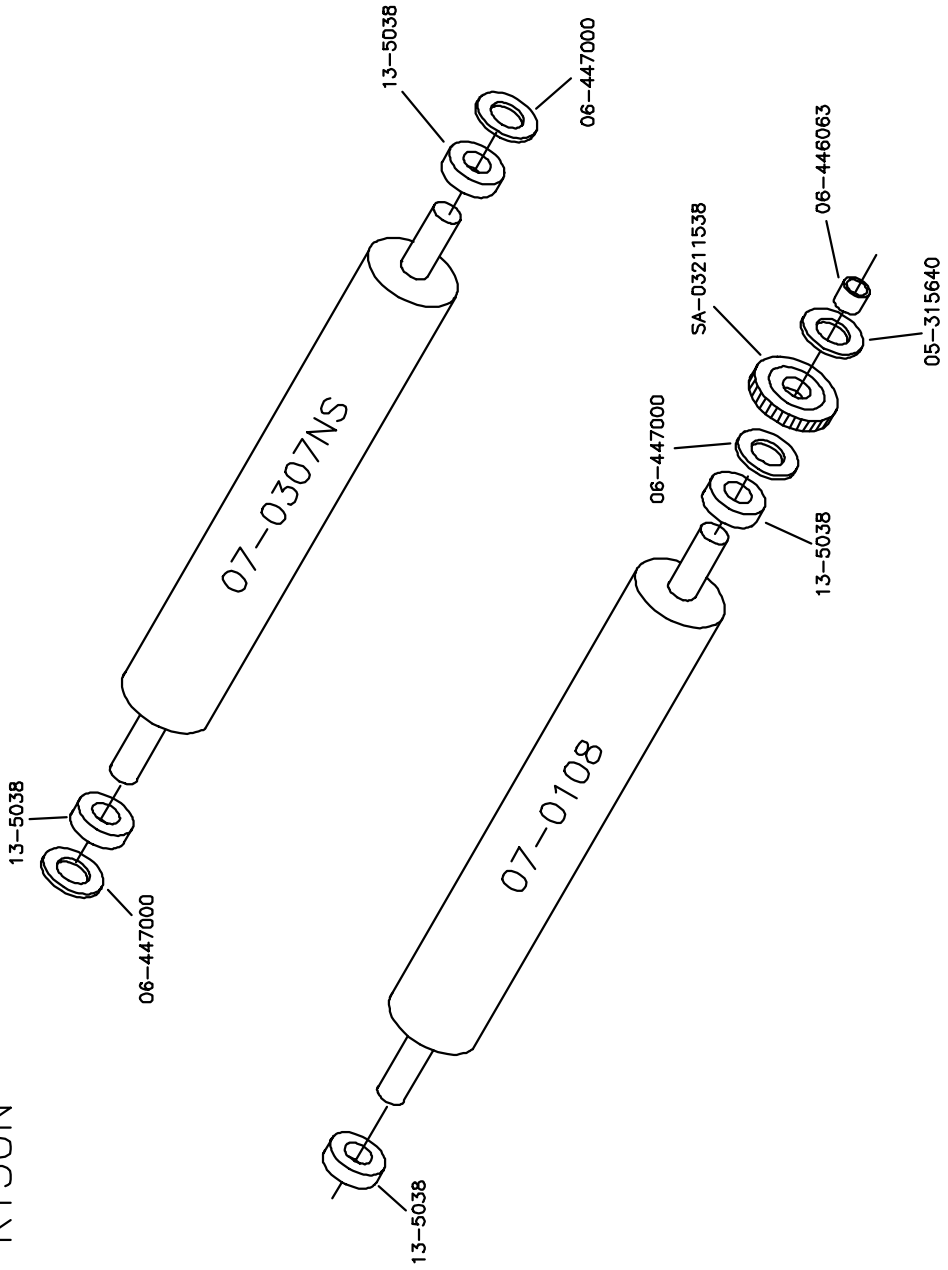

RY66, 8-96

RY50N

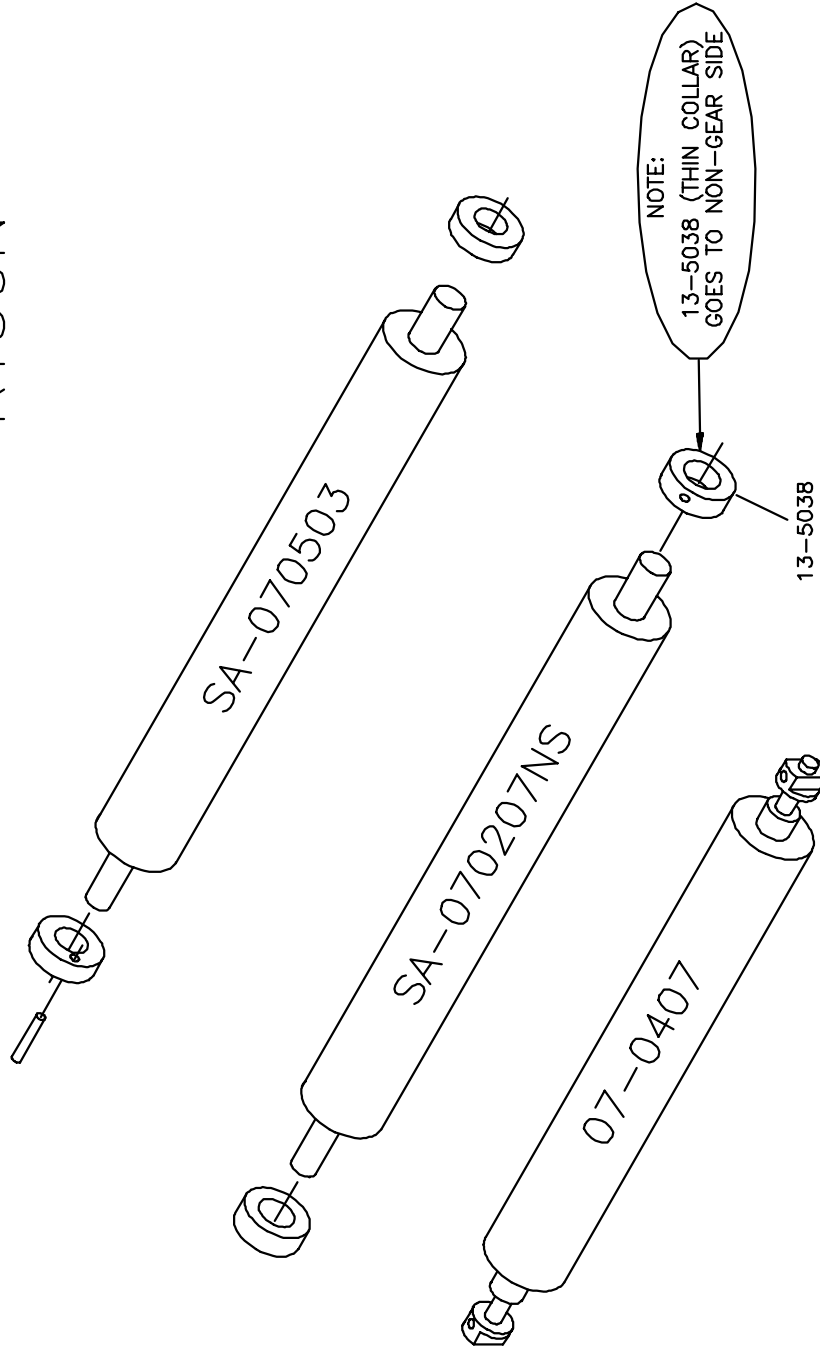

RY67, 8-96

RY500N

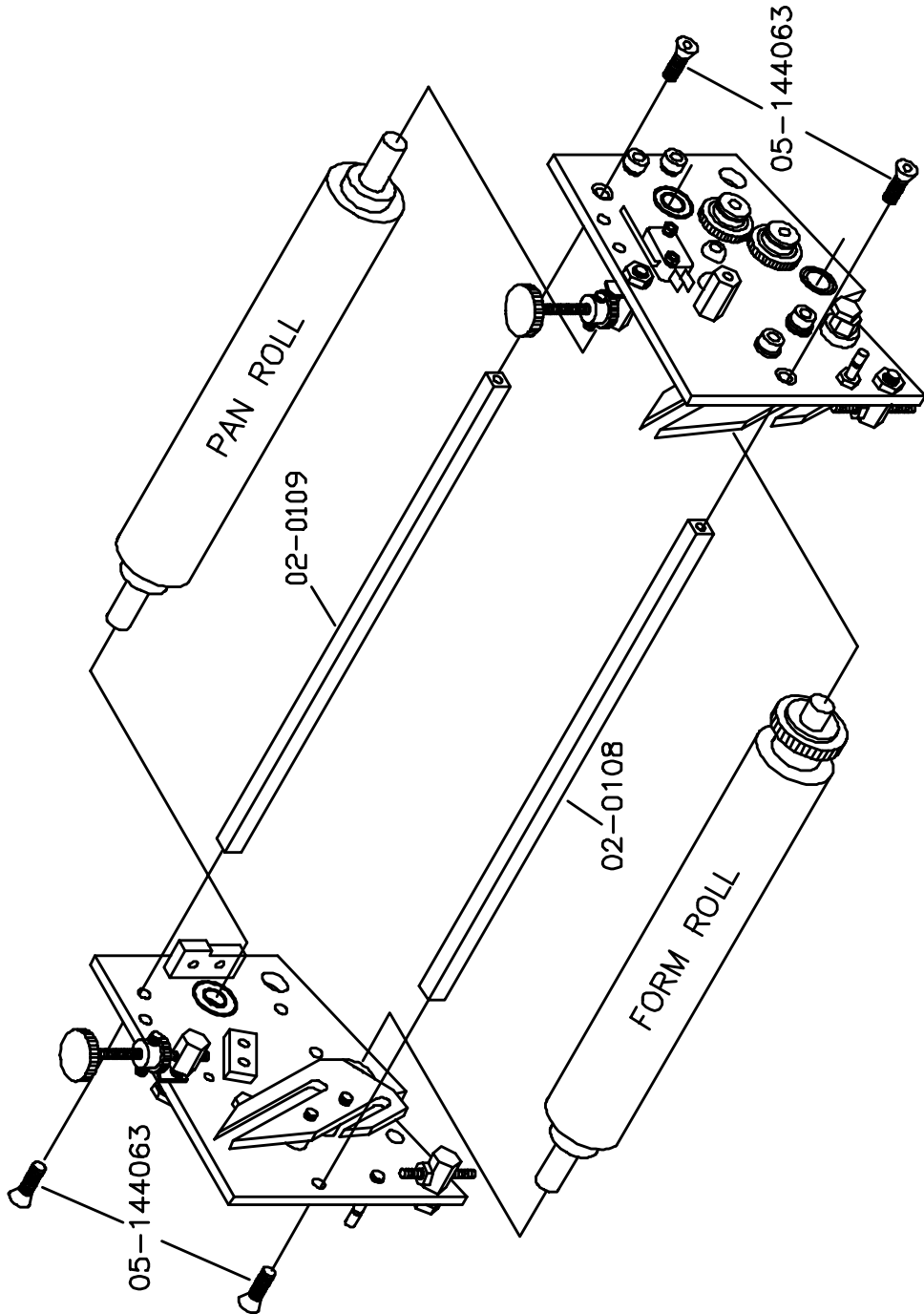

RY68, 6-97

RY50N

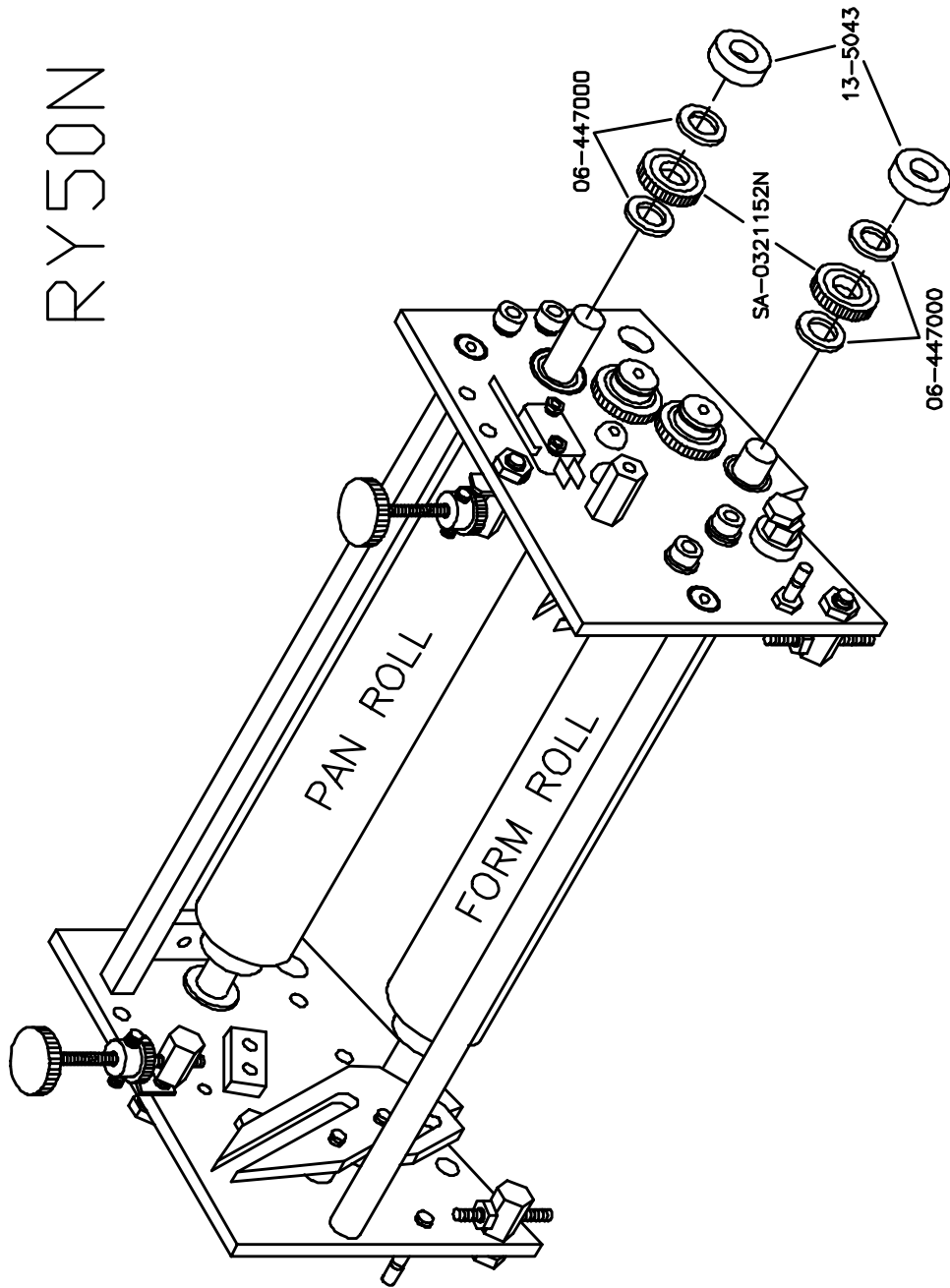

RYOBI 500N

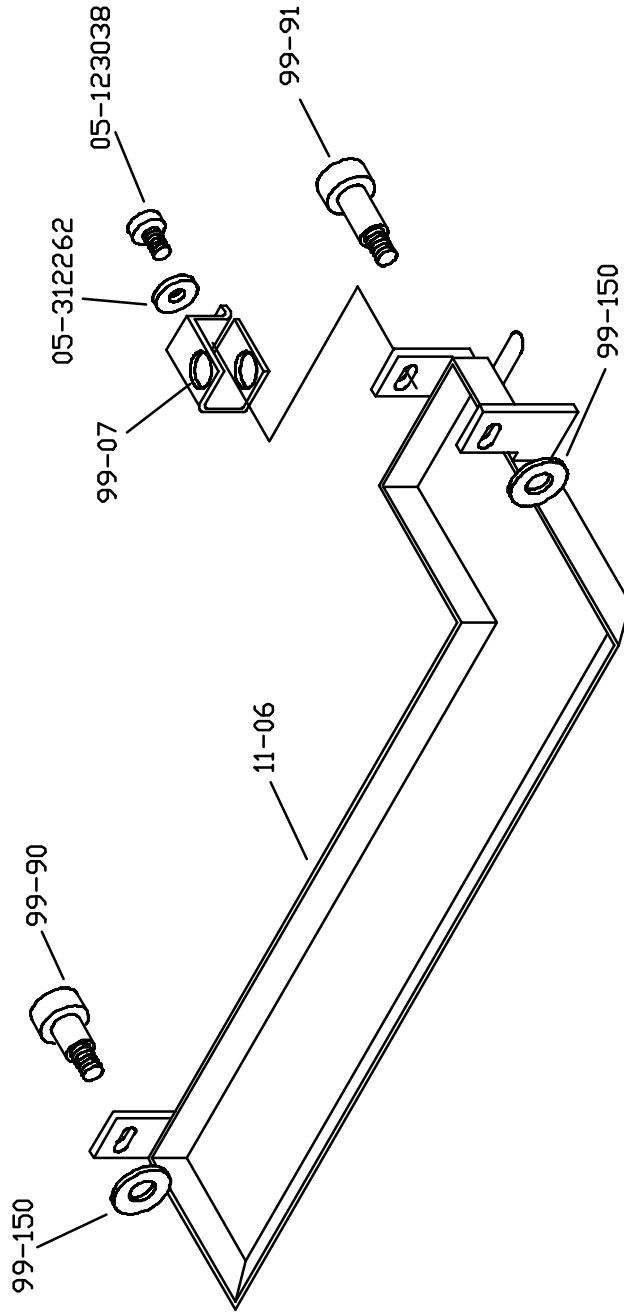

RY50N

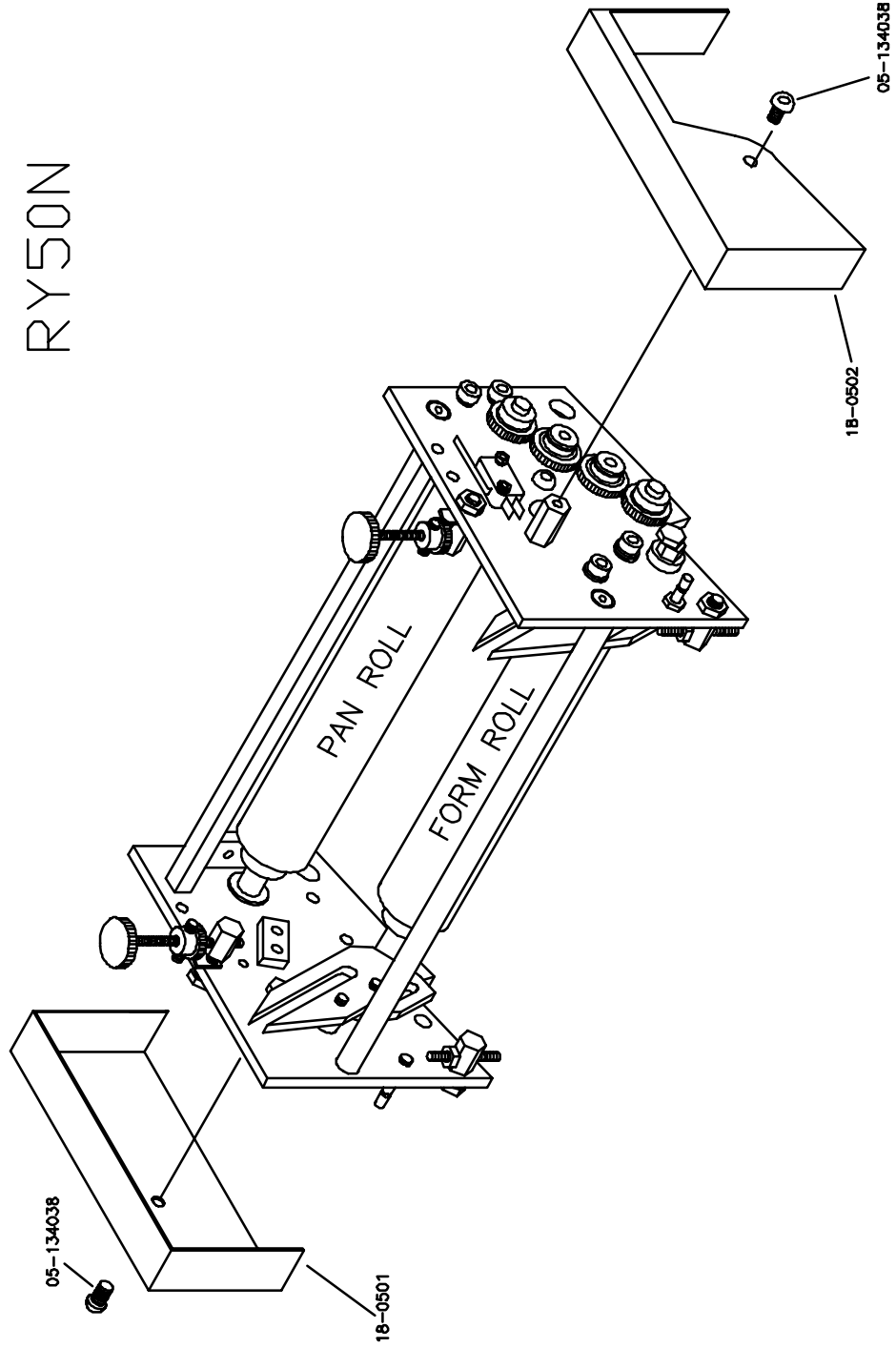

RY50N

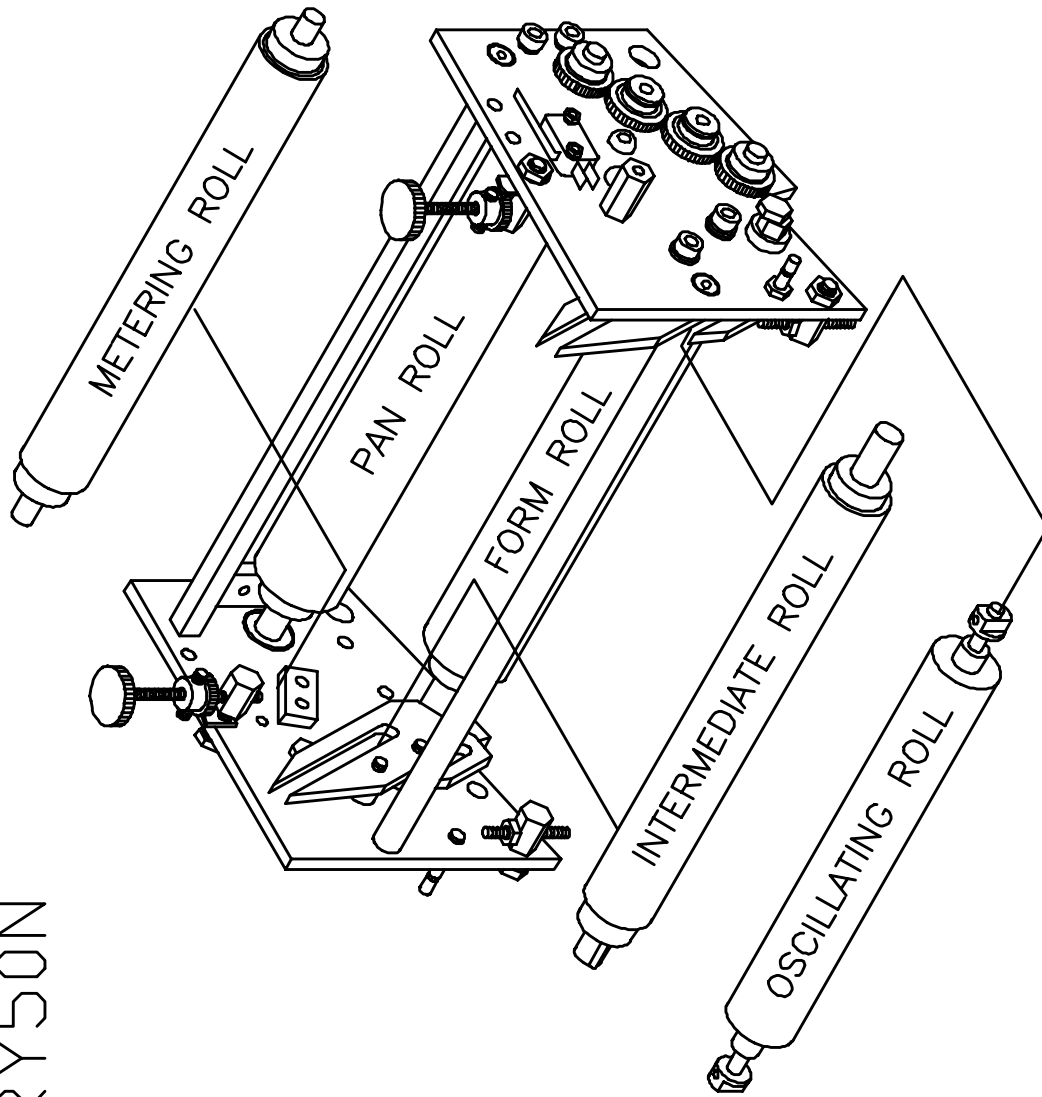

RYOBI 500N

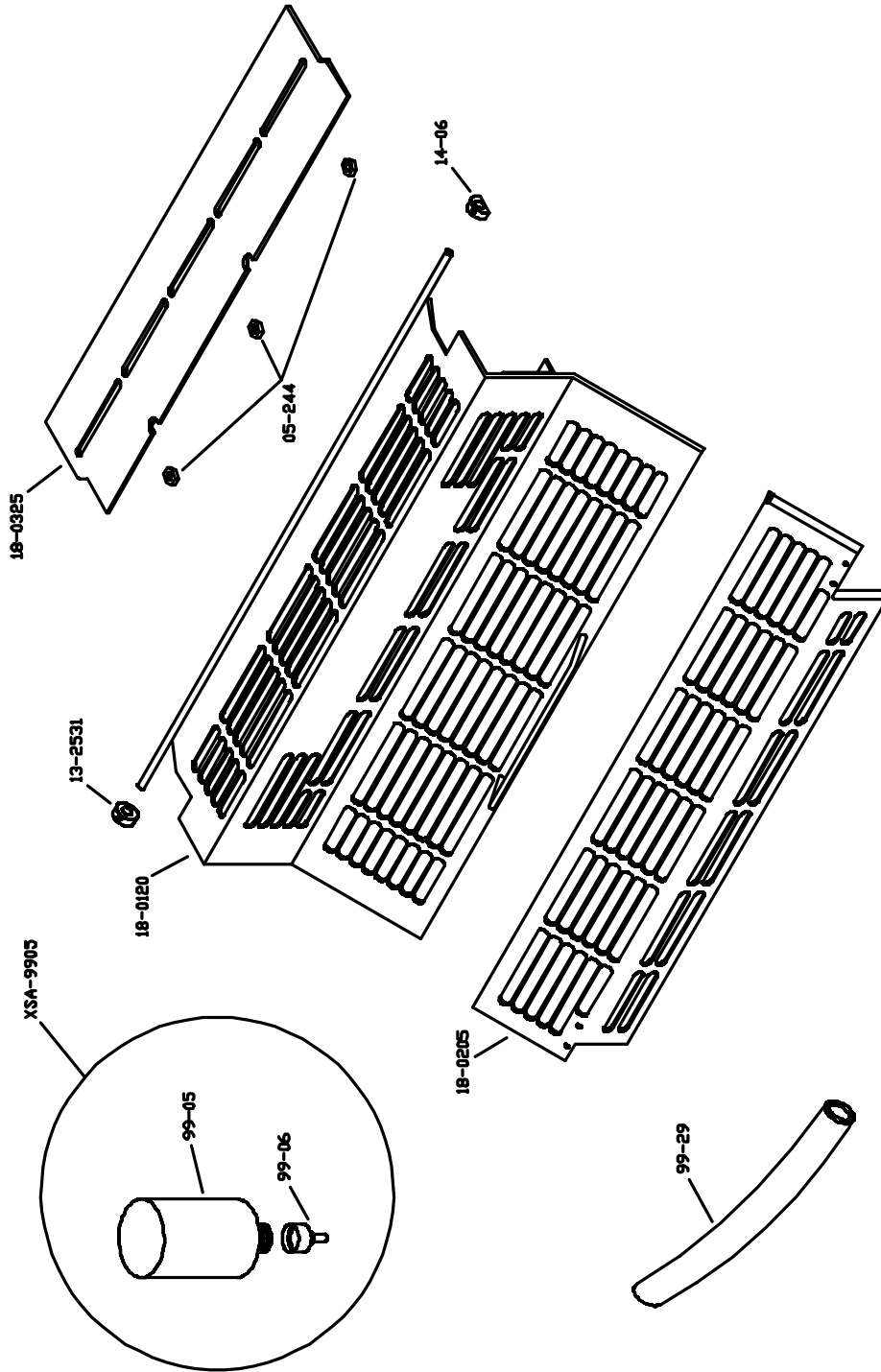

RY50N

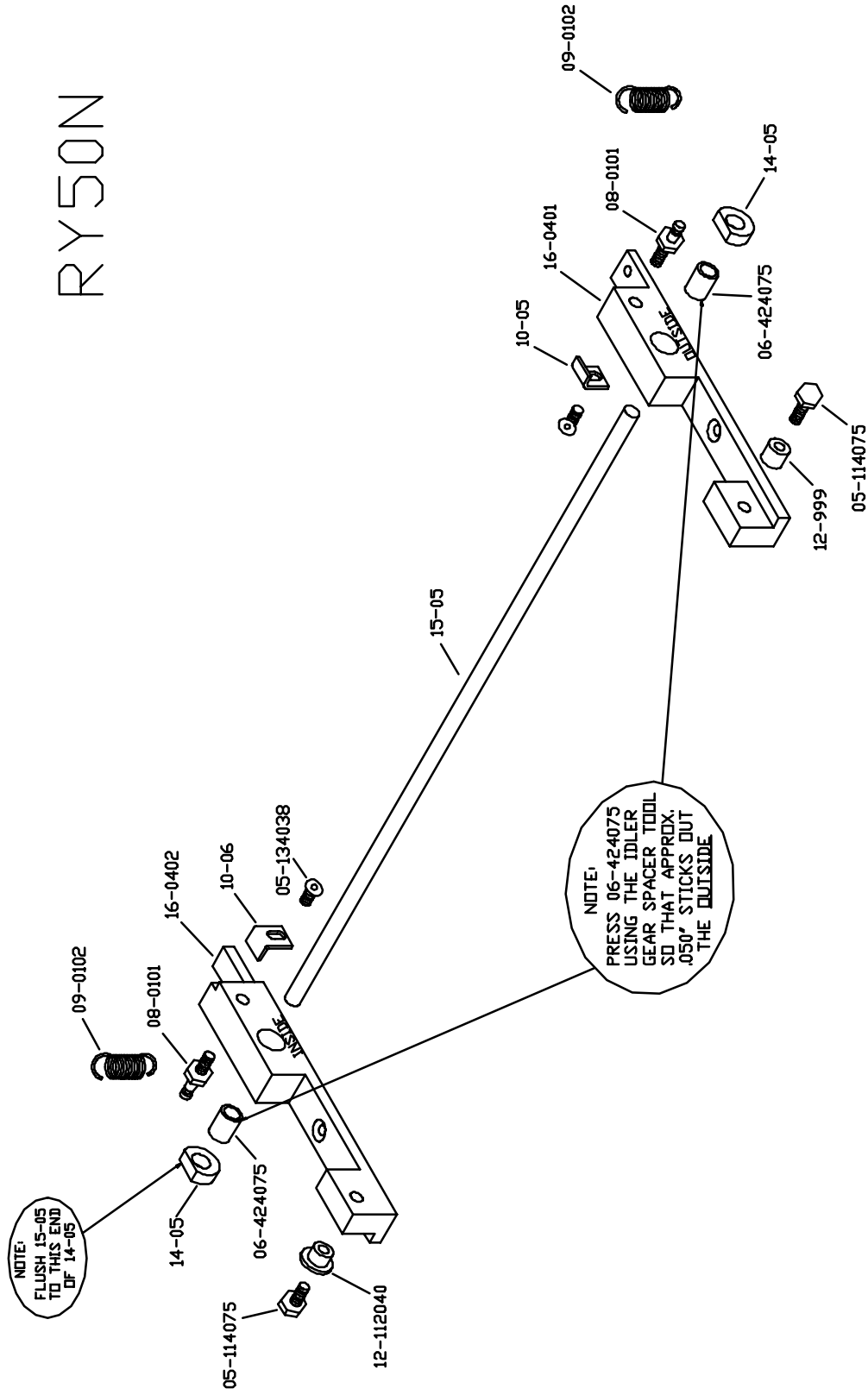

RY50N

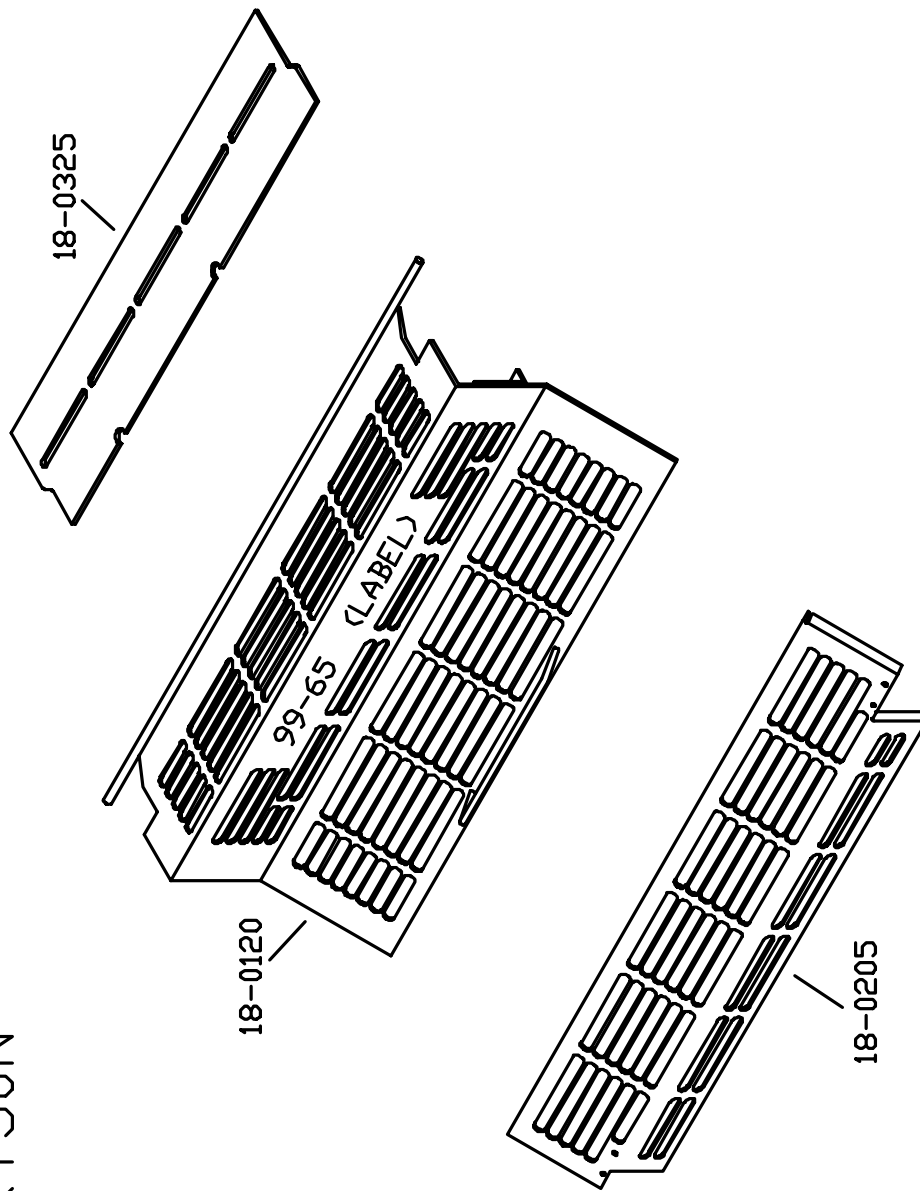

RY50N

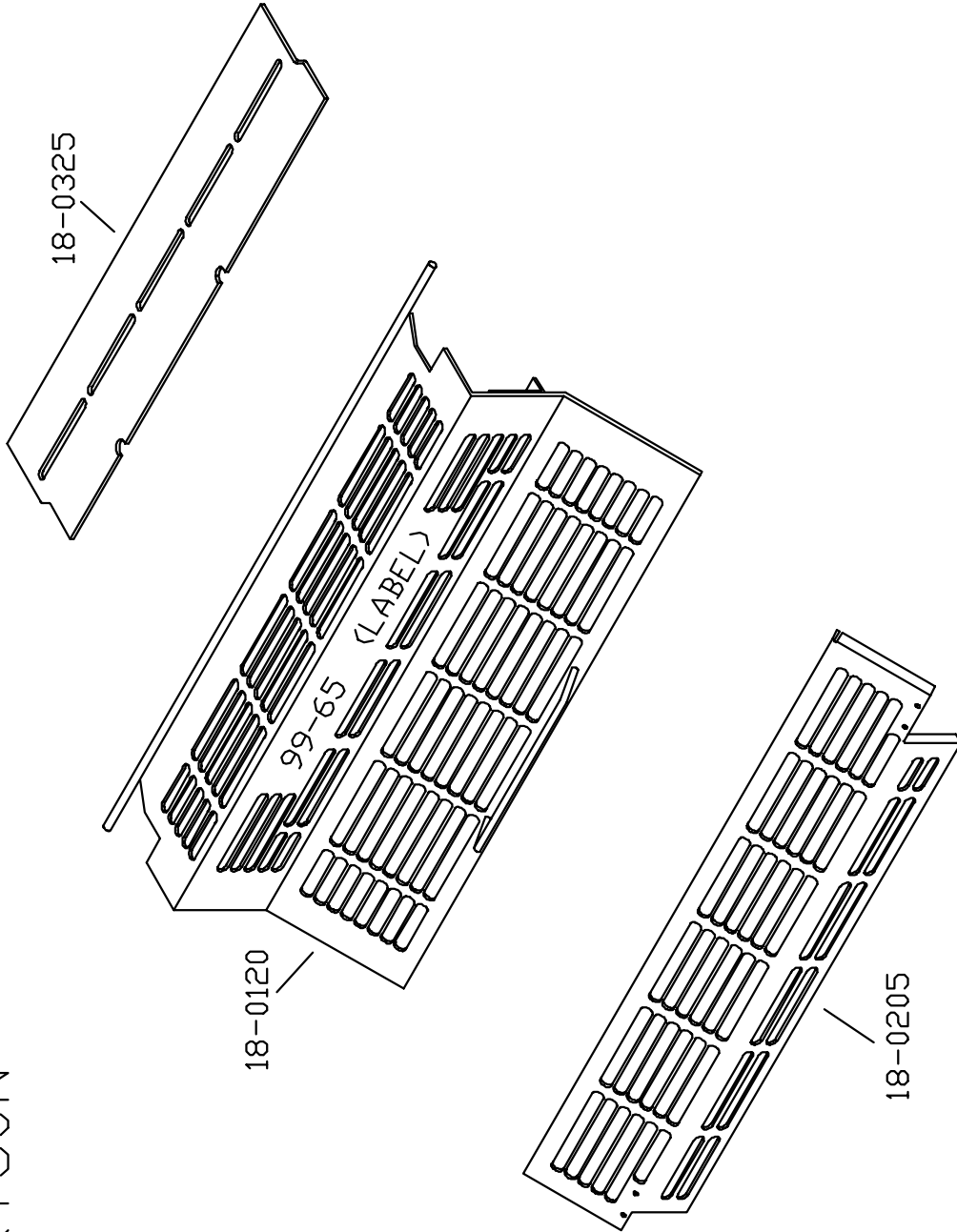

Quality Check

With the dampener viewed as shown, perform the following tests:

1. Spin the pan roller in the direction of the arrow. The gears on the outside should not spin.
2. Spin the form roller in the direction of the arrow. The gears on the outside should not spin.
3. Spin the form gear in the direction of the arrow. The gear should spin freely.

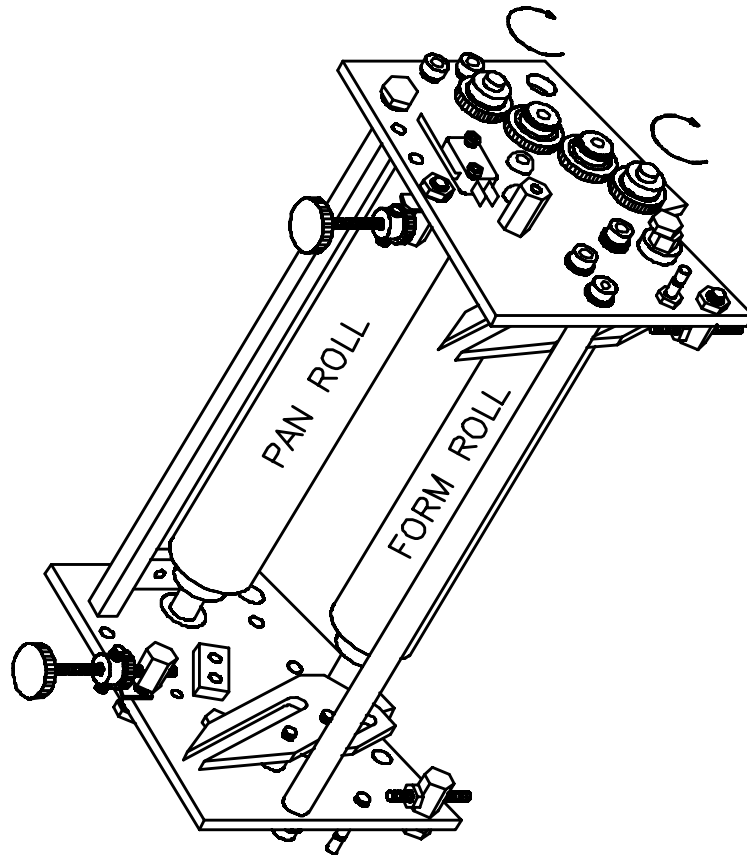

RYDBI 500N MOUNTING/ACTIVATING ASSEMBLY WITH SAFETY COVERS

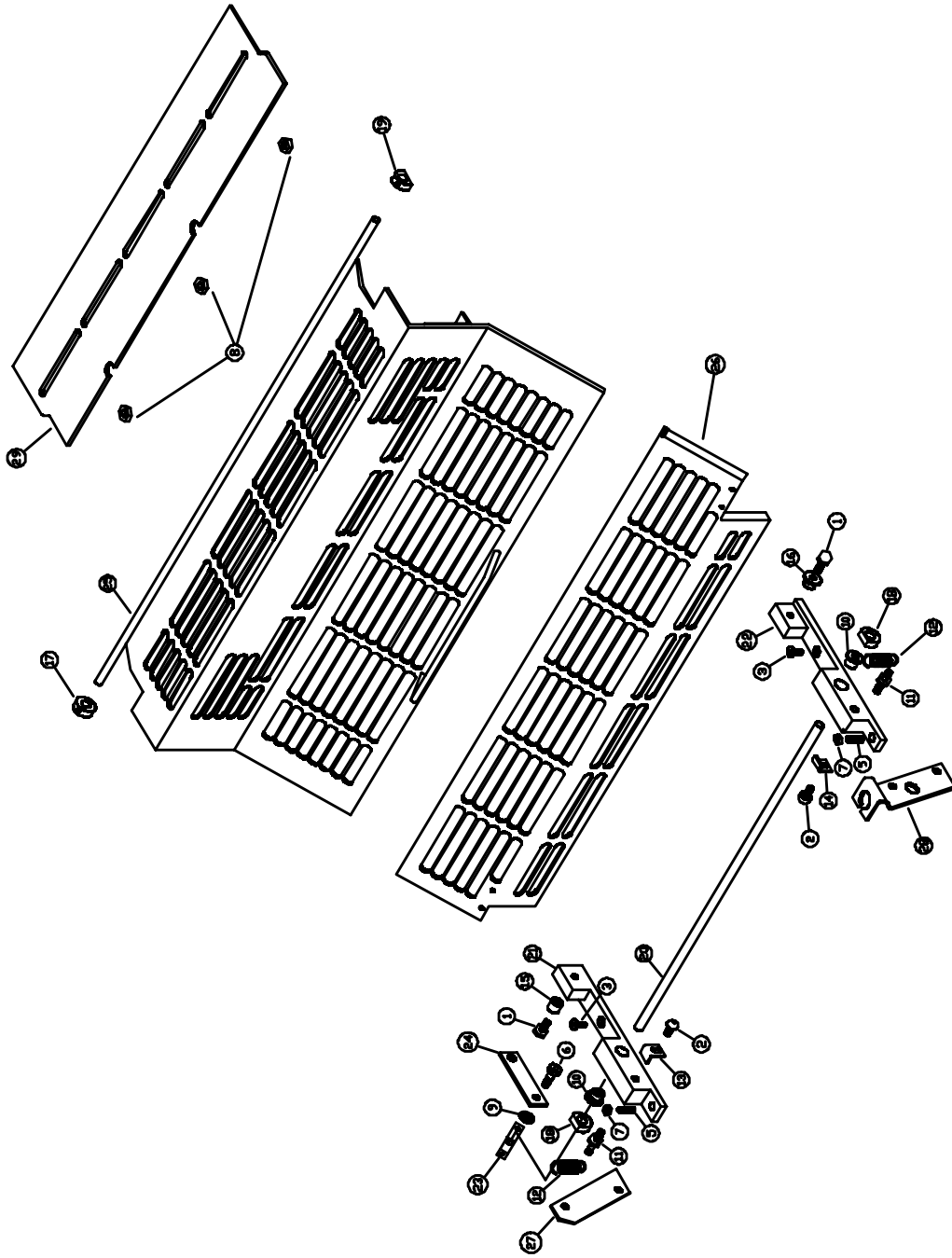

**MICROSWITCH INSTALLATION DIAGRAM
FOR RYOBI 500N**

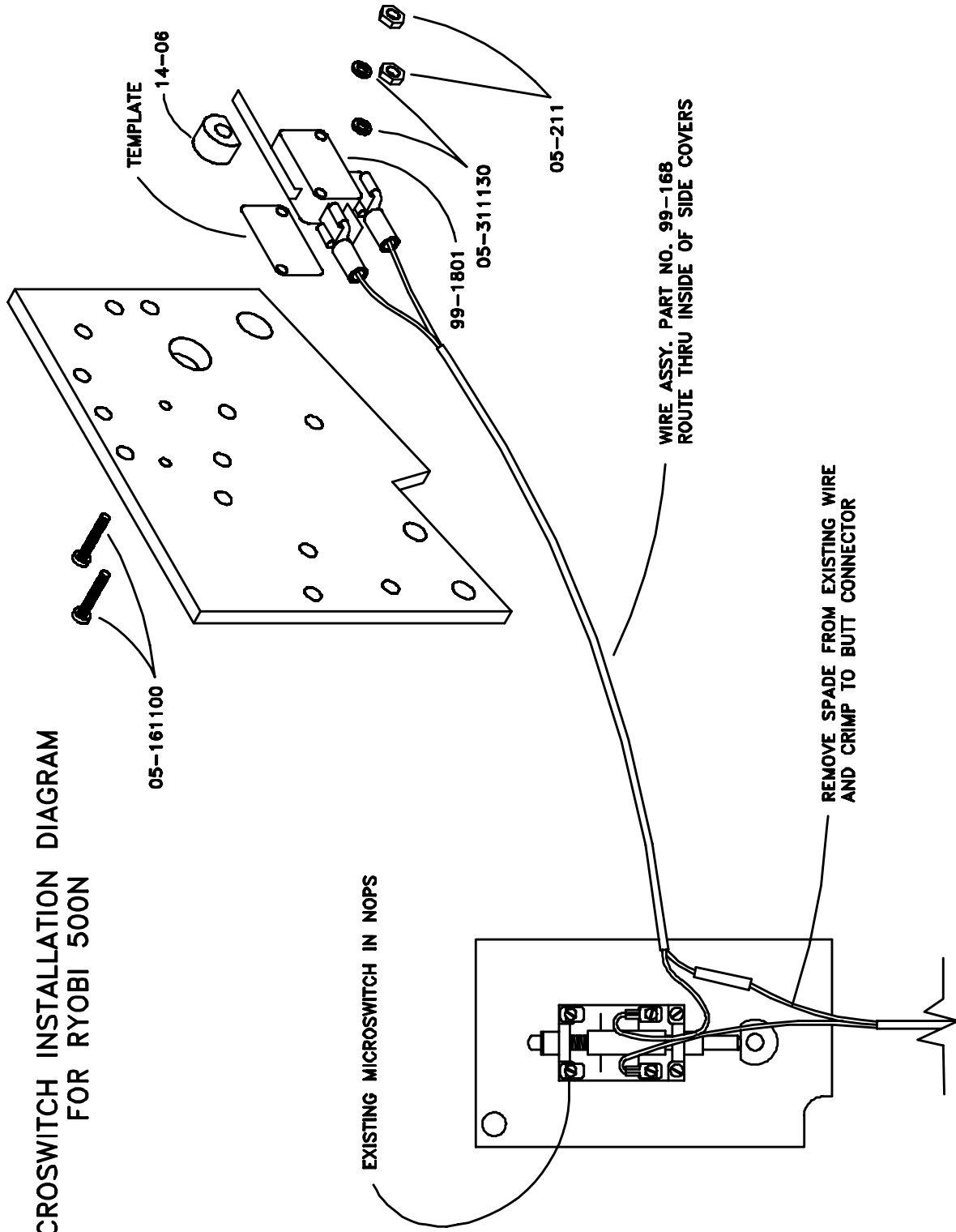

RYOBI 500N

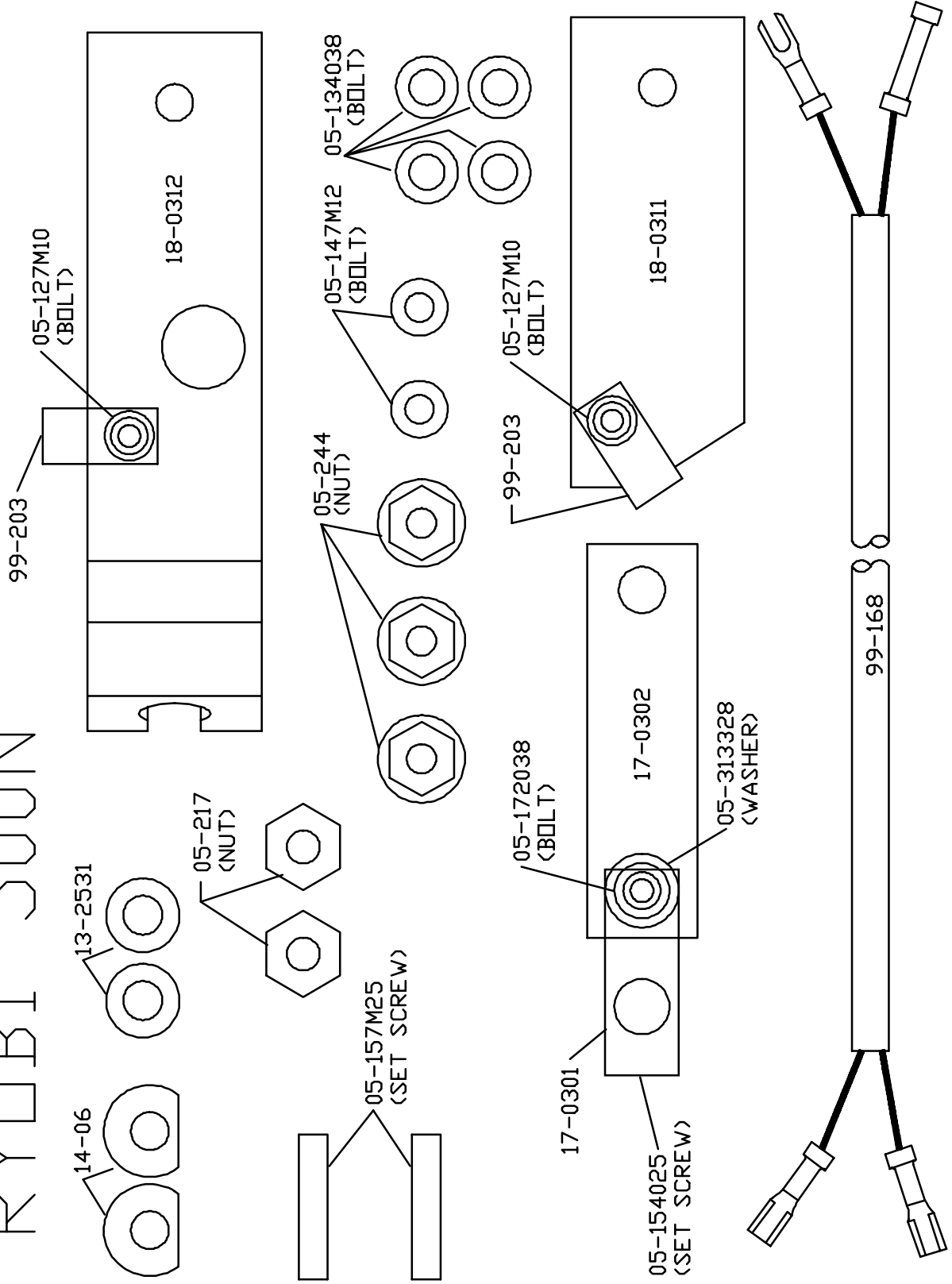

TheRollerStore.com ~ Fax 229.241.8023

TheRollerStore.com ~ Fax 229.241.8023

TheRollerStore.com ~ Fax 229.241.8023

ACCEL  [®]
Graphic Systems

11103 Indian Trail Dallas, TX 75229 Phone 972-484-6808, Fax 800-365-6510
E-Mail accel@dallas.net, Web Site accelgraphicsystems.com