

Parts Catalog

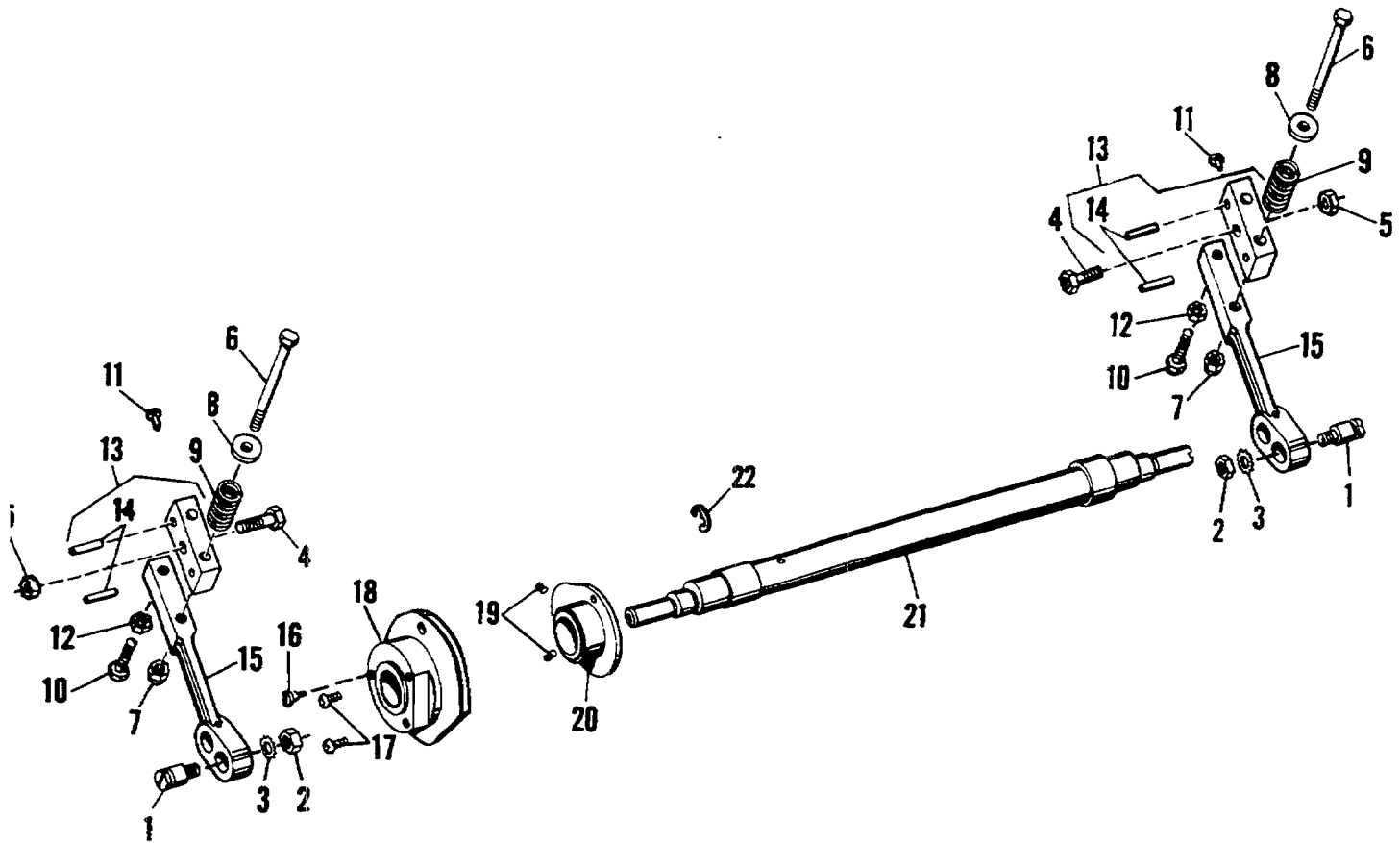

FIGURE 32
MODEL 9815/9850 Impression Cylinder Shaft and Support Arms

Parts Catalog

Index No.	Part No.	MODEL 9805/9850 Figure 32 Description	Units Per Assy.
1	080496	STUD - Support Arm	2
2	001845	NUT - 3/8-24	2
3	080495	WASHER - Lock, 25/64 I.D. x 1-1/4 O.D. x .119	2
4	014121	SCREW - 3/8-24 x 1.000	2
5	150089	NUT - 3/8-24	2
6	014172	SCREW - 1/4-28 x 3/4	2
7	001821	NUT - 1/4-28	2
8	080621	GUIDE - Support Arm Spring	2
9	078728	SPRING - Compression	2
10	014173	SCREW - 5/16-18 x 1-1/4	2
11	080447	PIN - Separator	2
12	001840	NUT - 5/16-18	2
13	080486	BLOCK ASSEMBLY - Support Arm, Impression Cylinder	2
14	001981	PIN - Roll, .199 O.D. x .827 O.A.L.	2
15	080498	SUPPORT ARM - Impression Cylinder	2
16	016158	SCREW - Shoulder, 10-32 x .273	1
17	001649	SCREW - 10-32 x .500	2
18	007729	CAM ASSEMBLY - Gripper, TD & QP	1
18	082129	CAM ASSEMBLY - Gripper, CD, QPC & PRO	1
19	100296	SCREW - Set, 1/4-28 x .500 Sq. Hd.	2
20	081037	CAM ASSEMBLY - Stripper, TD & QP	1
21	007609	SHAFT - Impression Cylinder	1
22	014517	RING - Retaining, 1.039 I.D. x .052	1