

**INSTALLING THE NORMALLY OPEN INTERLOCK
CONVERSION KIT (PART NO. 41787)**

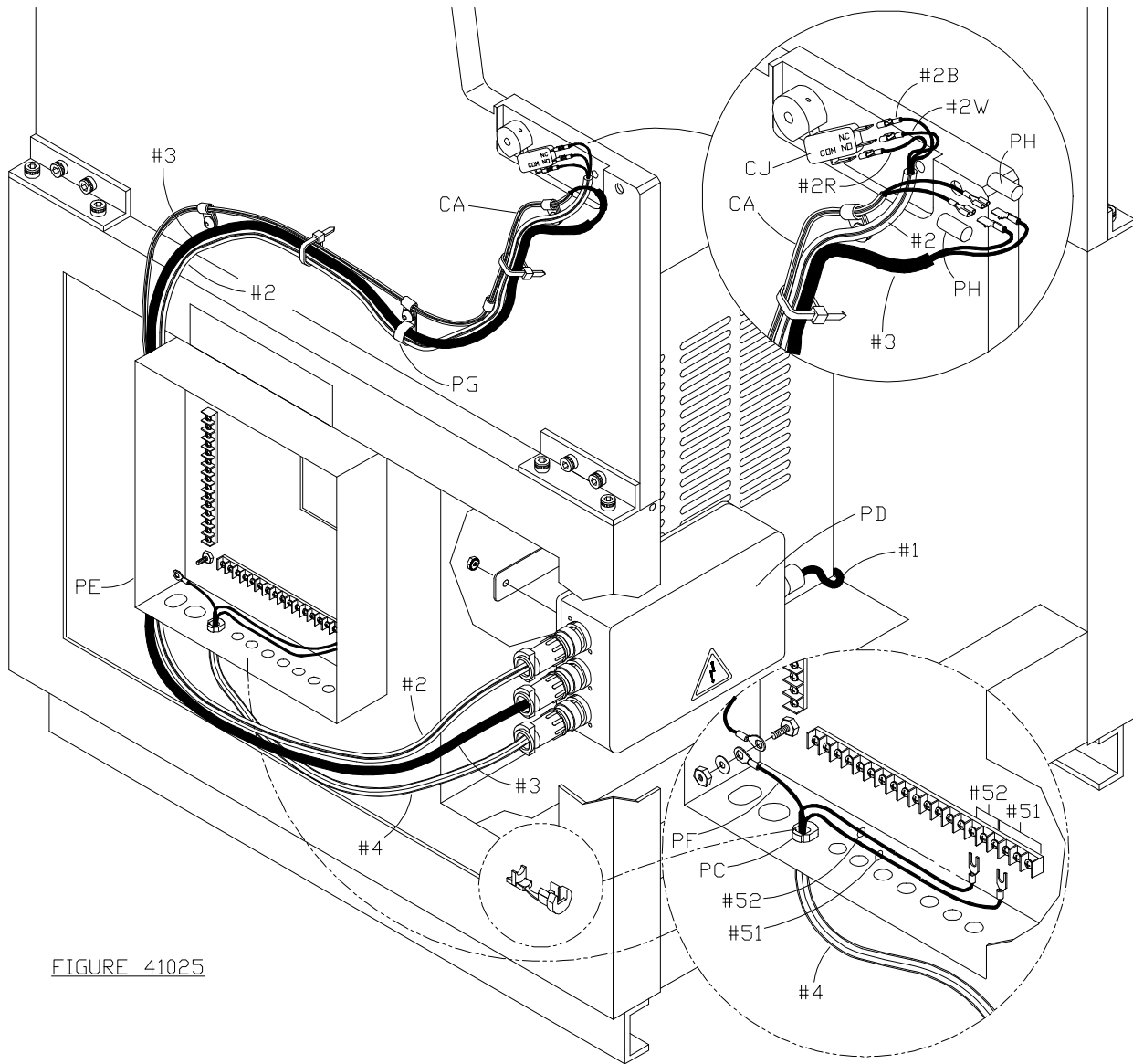

FIGURE 41025

INSTALLING THE NORMALLY OPEN INTERLOCK CONVERSION KIT (PART NO. 41787)

1. **WARNING:** Unplug the parent press.

Remove the operator and non-operator printing unit side covers, base frame side covers, and feeder side covers by removing the operating controls and cover screws. Center the control box (PD) below the feed table as shown. Mount it to the slotted plate, as low as possible, using the provided backing plate and nuts. Being careful to avoid any moving parts, route the #2, #3, and #4 harnesses under the parent press control box (PE). Each harness is numbered.

Remove the parent press control box cover. Insert the #4 harness through the hole in the bottom of the box and clamp it in the hole with the provided strain relief bushing (PC). The parent press cable tie(s) used to secure the harnesses outside the box may have to be removed and the harnesses pushed out of the way to allow access.

Connect #4 harness as follows:

- GREEN (PF) to the control box grounding stud, being sure the nut is tight when it is replaced.
- #51 (RED) and #52 (BLACK) to the #51 and #52 locations on the parent press control box terminal strip.

Use the provided 4-1/2 inch (114mm) cable ties to attach the wires to the control box terminal strip wire bundle. Replace the control box cover.

2. Install the provided 1/2 inch wire harness clamp (PG) in the same location as the middle parent press wire harness clamp using the parent press screw. The clamp size is embossed onto the clamp. Route the #2 and #3 harnesses along the parent press wire harness (CA) to the parent press interlock switch, being sure to pass the harnesses through the 1/2 inch clamp. Disconnect the parent press wire harness from the switch (CJ).

Connect #2 harness as follows:

- | | | |
|------------------|----|----------------------------|
| - #2 RED (#2R) | to | - switch (CJ) COM terminal |
| - #2 WHITE (#2W) | to | - " " NO terminal |
| - #2 BLACK (#2B) | to | - " " NC terminal |

Connect #3 harness to the parent press wire harness (CA) using the provided heat shrink insulators (PH) to insulate the terminals.

Being careful to avoid any moving parts, use the provided 4-1/2 inch (114mm) cable ties to secure the #2 and #3 harnesses to the parent press wire harness down to the parent press control box. Replace any cable ties that were removed using the provided assortment of 4-1/2 inch (114mm), 5-3/4 inch (147mm), and 10-3/4 inch (275mm) cable ties.

WARNING: BE SURE ALL GUARDS, COVERS, AND SAFETY DEVICES ARE INSTALLED AND PROPERLY ADJUSTED BEFORE OPERATING THIS UNIT. IF THE T-51 IS REMOVED FROM THE PARENT PRESS, THE ORIGINAL GUARDING *MUST* BE REPLACED BEFORE OPERATING THE PRESS. WHEN THE T-51 IS SWUNG OFF TO THE SIDE, THE REPLACEMENT SAFETY GUARD *MUST* BE USED BEFORE OPERATING THE PRESS.

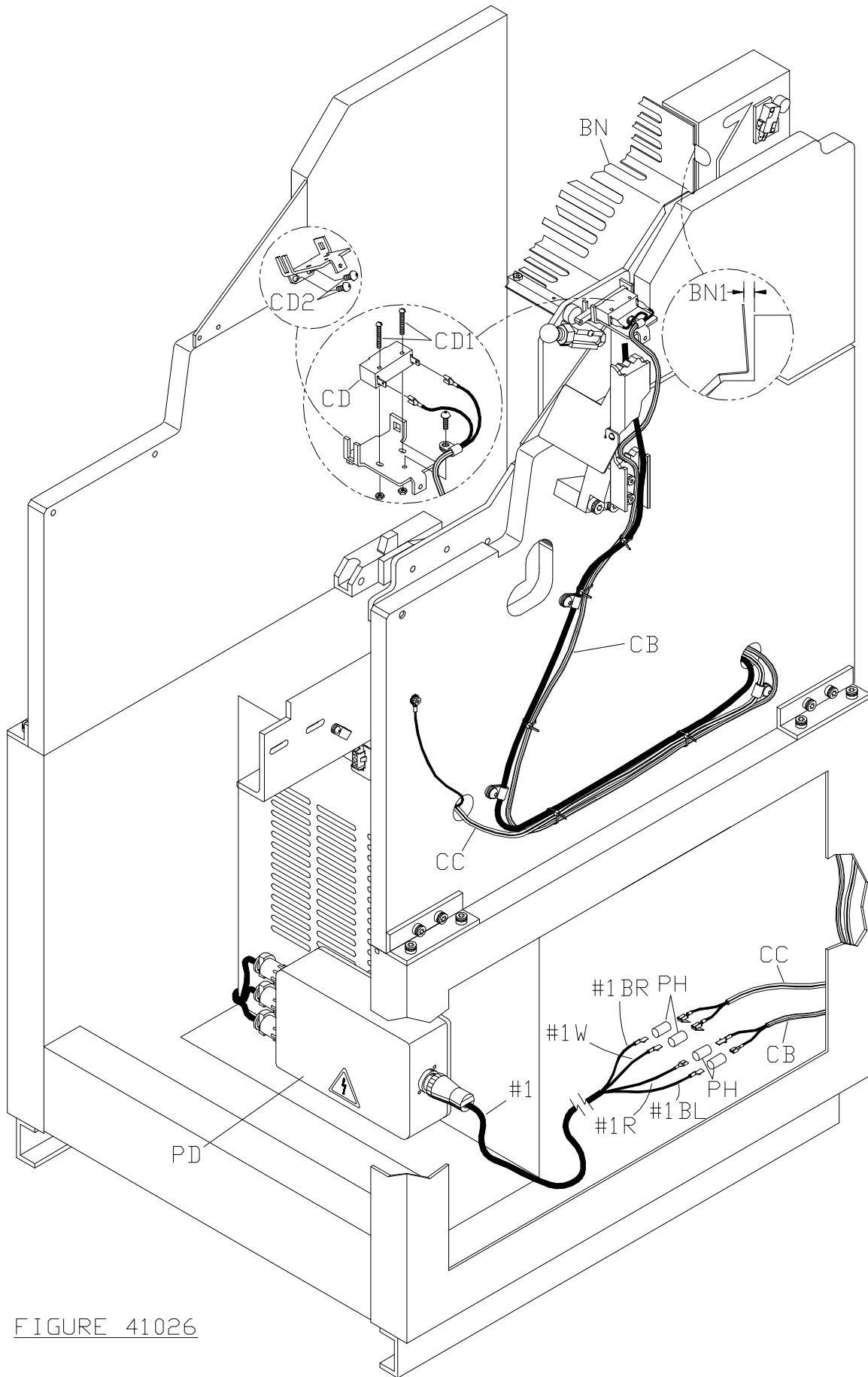

FIGURE 41026

INSTALLING THE NORMALLY OPEN INTERLOCK CONVERSION KIT (PART NO. 41787)

3. Being careful to avoid any moving parts, route the wire harness (CB) that is plugged onto the interlock switch (CD) and wire harness (CC) along the parent press wire harness. Pass the harnesses through the side frame hole and route them down the inside of the base frame vertical frame member.

Route the #1 harness along the inside of the base frame horizontal frame member.

Connect the #1 harness as follows using the provided heat shrink insulators (PH) to insulate the terminals.

- BROWN (#1BR) and WHITE (#1W) to wire harness (CC) piggyback connectors (no particular order)
- RED (#1R) and BLACK (#1BL) to wire harness (CB).

Being careful to avoid any moving parts, use the provided assortment of cable ties to secure the wire harnesses to the parent press.

4. Plug in the parent press. The parent press should turn off when the guard (BN) is opened slightly less than 1/2 inch (12mm). This is measured between the lead edge of the guard and the parent press safety cover as is indicated by the dimension (BN1). The interlock switch sensitivity can be adjusted by accessing the screws (CD1) and (CD2) in the slotted bracket holes

Refer to Figure 42003 in the Ryobi 2800 T-51 manual or Figure 41003 in the Ryobi 3200 T-51 manual. Adjust the cam (AF2) so that the parent press turns off when guard (BP) is opened slightly less than 1/2 inch (12mm). This is measured between the guard and guard pivot bar as is indicated by the dimension (BP3) at the specified location.

WARNING: Unplug the parent press.

Be sure to keep these instructions with your T-51 manual for future reference!

WARNING: Failure to install and comply with the interlock conversion kit installation instructions may lead to EQUIPMENT DAMAGE and/or **PERSONAL INJURY**.

WARNING: BE SURE ALL GUARDS, COVERS, AND SAFETY DEVICES ARE INSTALLED AND PROPERLY ADJUSTED BEFORE OPERATING THIS UNIT. IF THE T-51 IS REMOVED FROM THE PARENT PRESS, THE ORIGINAL GUARDING *MUST* BE REPLACED BEFORE OPERATING THE PRESS. WHEN THE T-51 IS SWUNG OFF TO THE SIDE, THE REPLACEMENT SAFETY GUARD *MUST* BE USED BEFORE OPERATING THE PRESS.